

Power flow analysis for grid connected DGs and battery based transformer coupled Bidirectional DC-DC converter

Dr. M.Padma Lalitha¹
*Professor & HOD*¹

N.Sree Ramula Reddy²
*Assistant professor*²

N.Gurutheja³
*PG scholar*³

Abstract

In this project a compose method for power stream organization of a matrix related blend Photovoltaic-vitality component wind based framework with a proficient transformer appended double directional dc-dc converter is shown. The purpose of our venture is to satisfy the heap ask for, manage the power spill out of different sources, embed overabundance control interested in the structure and accusation the energy source from matrix as and when essential. A transformer appended step up half-connect converter be apply to handle control from wind, even as double directional step down-step up converter is used to seat control from Photovoltaic next to by string absorbing/delivering put in order. A solitary stage full-connect double directional converter is used for nourish air conditioning burdens and correspondence with structure. The future converter configuration has decreased number of influence trade stages with less component check, and diminished adversities appeared differently in relation to available structure related blend framework. By then we will test the single stage multi 5-level converter to bolster air conditioning burdens and correspondence with structure. Recreation results are gotten utilized MATLAB/Simulink.

Keywords: Hybrid system, solar photovoltaic, wind energy, transformer attached boost dual-half-connect double directional converter, dual directional step down-step up converter, maximum power point tracking, full bridge dual directional converter, battery charge control.

I. PREFACE

In consolidated converters for Photovoltaic, wind, vitality frameworks are displayed. Photovoltaic-wind combination framework, arranged has an essential power phrasing anyway it is fitting for stay single applications. Blend Photovoltaic-velocity base era of energy and its intersection point through the control structure are the fundamental investigate districts. This framework is sensible for residential applications, wherever an insignificant exertion, fundamental and diminished system prepared for self-representing operation is alluring. A control plot for fruitful power stream organization to give constant power supply to the heaps, while imbuing excess control into the structure is future. In this way, the arranged course of action and control scheme give a rich coordination of Photovoltaic and wind influence asset.

II. FUTURE CONVERTER DESIGN

The arranged converter involves a transformer appended step up half-connect bidirectional converter consolidated with bidirectional step down-step up converter and a lonely stage full-connect inverter. The system is fundamental and wants only six control switches. The schematic layout of the anticipated converter in Fig.1. The improve step up half-connect converter has double bus-interfaces on both sides of the high rate transformer. Also, assist converters can be facilitated among a few of the two dc-joins. A double directional step down-step up dc-dc converter is synchronized with the fundamental side dc-association and single-stage full extension double directional converter is related with the dc-association of the helper side. Exactly when turn T_3 is executed and T_4 is bent going ahead, at first the inductor current courses through against parallel diode of switch T_4 and through the capacitor bank. All through the period, the present coursing through diode reduces and that is traveling through transformer fundamental increments. Right when current traveling through the inductor gets the chance to be unmistakably proportionate to that traveling through transformer essential, the diode murders. Since, T_4 is gated ON in this time, the capacitor C_2 now discharges through switch T_4 and transformer basic. Amid the ON time of T_4 , against parallel diode of progress T_6 practices to charge the capacitor C_4 .

In the middle of the ON time of T_3 , the basic voltage $V_P = -V_{C1}$. The assistant voltage $V_S = nV_p = -nV_{C1} = -V_{C3}$, or $V_{C3} = nV_{C1}$ and voltage crosswise over fundamental

inductor L_w is V_w . At the point when T_3 is killed and T_4 turned ON, the fundamental voltage $V_P = V_{C2}$. Assistant voltage $V_S = nV_P = nV_{C2} = V_{C4}$ and voltage crosswise over basic inductor L_w is $V_w - (V_{C1} + V_{C2})$. It can be demonstrated that $(V_{C1} + V_{C2}) = V_w/(1-D_w)$. The capacitor voltages are measured regular in stable condition with the resolve at $V_{C3} = nV_{C1}$, $V_{C4} = nV_{C2}$.

Hence the output voltage is given by

$$VDC = VC3 + VC4 = n \frac{V\omega}{1-D\omega} \tag{1}$$

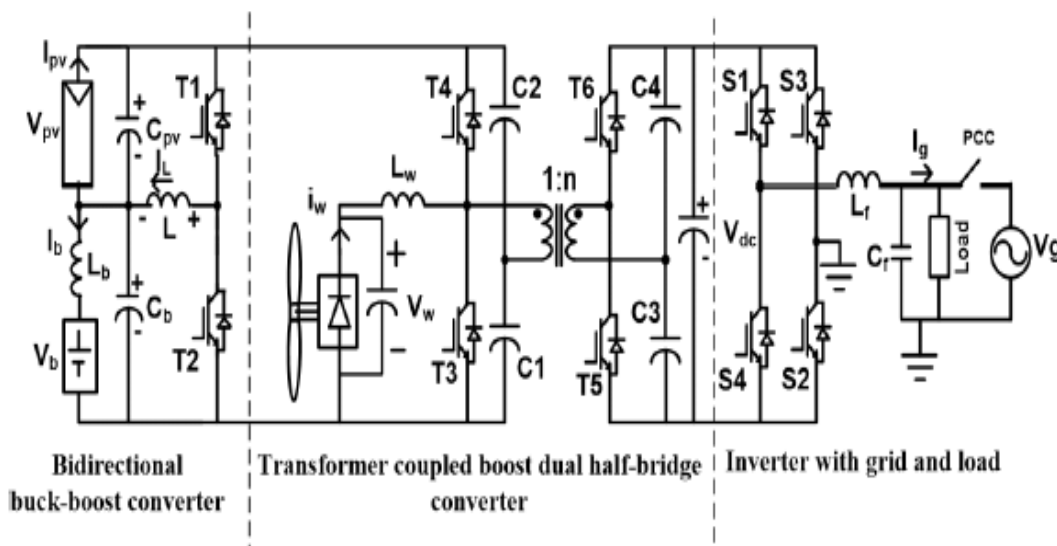

Fig.(1). Block diagram of conventional converter

In the above Fig.1, a bidirectional step down-step up converter is use for Maximum power point following of Photovoltaic come together and string absorbs/releasing oversees. Encourage this double directional stride up Venture down inverter absorbs/delivers the capacitor bank C_1 - C_2 of transformer joined half-interface bolster converter in light of the heap request. Right when turn T_1 is executed and T_2 is twisted taking place, imperativeness set away in L is traded to the battery. If the string delivering modern is more than the Photovoltaic current, inductor current ends up noticeably negative. Here, the put away vitality in the inductor increases when T_2 is crooked taking place along with reduces when T_1 is curved going on. It can be exhibited that $V_b = D/(1-D) V_{pv}$. The yield potential difference of the transformer joined lift half-interface converter is given by,

$$V_{dc} = n(V_{C1} + V_{C2}) = n(V_b + V_{PV}) = \frac{nV_w}{1 - D_w} \tag{2}$$

The association between the typical estimation of inductor, Photovoltaic and vitality source current over a trading cycle is given by $I=I_b+I_{pv}$. Thus, the Maximum power following operation is ensured by controlling IL, while keeping up suitable energy source absorption intensity. I_L is used as internal circle control parameter for faster element reaction while for outer circle, capacitor voltage crosswise over photovoltaic source is used for enables Maximum power following potential difference.

III. FUTURE CONTROL COORDINATION FOR POWER FLOW ORGANIZATION

For this circumstance, the power modify is refined in absorbing the string until it accomplishes its most noteworthy absorbing present uttermost point I_{bmax} . In the wake of accomplishing this purpose of constringent, to ensure controls alter one of the sources or both need to stray from their Maximum power point control in light of the heap asks. In the structure associated framework both the sources dependably work at their Maximum power point. Without together the supplies, the control is pulled in from the system to charge the vitality source as and keeping in mind that necessary. The stipulation for the power adjust of the framework is given by

$$V_{pv}I_{pv} + V_W I_W = V_b I_b + V_g I_g \quad (3)$$

The maximum value of the stream voltage for a single-stage full-connect converter,

$$\hat{V} = m_a V_{dc} \quad (4)$$

and the bus-link voltage is,

$$V_{dc} = n (V_{pv} + V_b) \quad (5)$$

Hence, by substituting for Vdc in (4), gives,

$$V_g = \frac{1}{\sqrt{2}} m_a n (V_{pv} + V_b) \quad (6)$$

In the step down half-connect converter,

$$V_w = (1 - D_w)(V_{pv} + V_b) \quad (7)$$

Now substituting Vw and Vg in (3),

$$V_{pv}I_{pv} + (V_{pv} + V_b)(1 - D_w)I_w = V_b I_b + \frac{1}{\sqrt{2}} m_a n (V_{pv} + V_b) I_g \quad (8)$$

After simplification,

$$I_b = I_{pv} \left(\frac{1-D_{pv}}{D_{pv}} \right) + I_w \left(\frac{1-D_w}{D_{pv}} \right) - I_g \left(\frac{m_a n}{\sqrt{2} D_{pv}} \right) \quad (9)$$

IV. VERIFICATION BY SIMULINK

TABLE I model constraint

Parameter	Value
Solar PV power	525W ($I_{mpp}=14.8A$) ($V_{mpp}=35.4V$)
Wind power	300W ($I_{mpp}=8A$) ($V_{mpp}=37.5V$)
Switching frequency	15kHz
turns ratio	5.5
Inductor-half bridge boost converter, $L\omega$	$500\mu H$
Inductor-dual directional converter L	$3000\mu H$
Essential side capacitors C_1-C_2	$500\mu F$
Auxiliary side capacitors C_3-C_4	$500\mu F$
Auxiliary side capacitor total dc-bus	$2000\mu F$
Battery capacity & voltage	400Ah, 36V

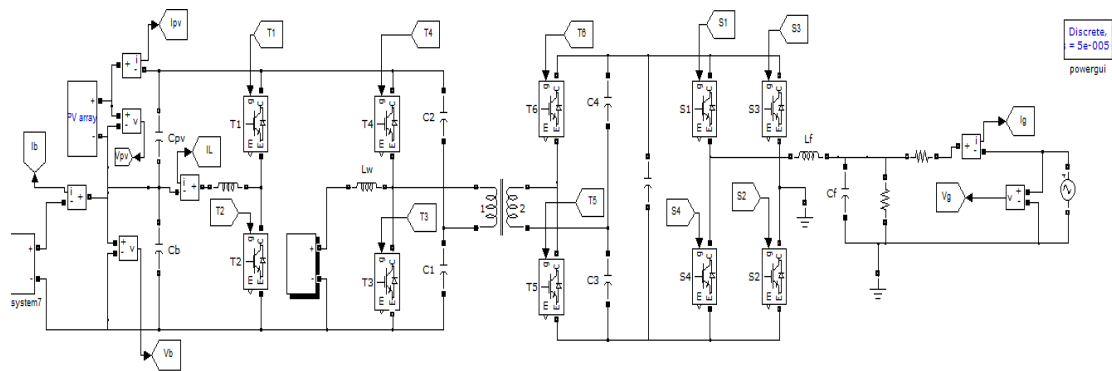

Fig.2.conventional method of Simulation block diagram

V. SIMULATION RESULTS

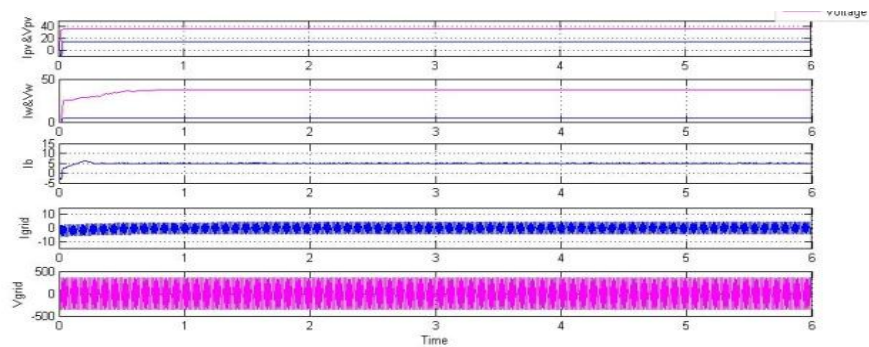

Fig.3. I_{pv} and V_{pv} , I_w and V_w , I_b , I_{grid} and V_{grid} when both PV and wind sources are active

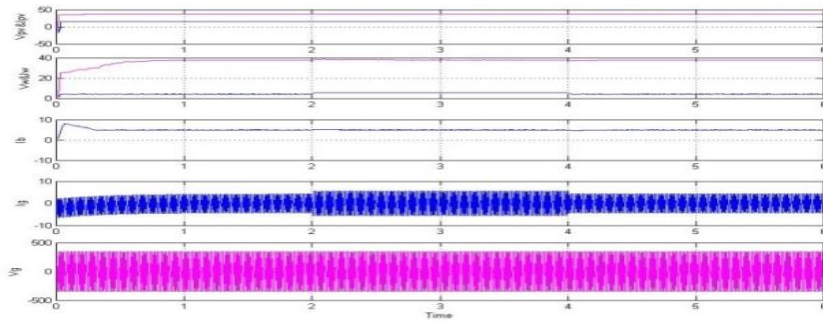

Fig.4. I_{pv} and V_{pv} , I_w and V_w , I_b , I_{grid} and V_{grid} When wind sources increases

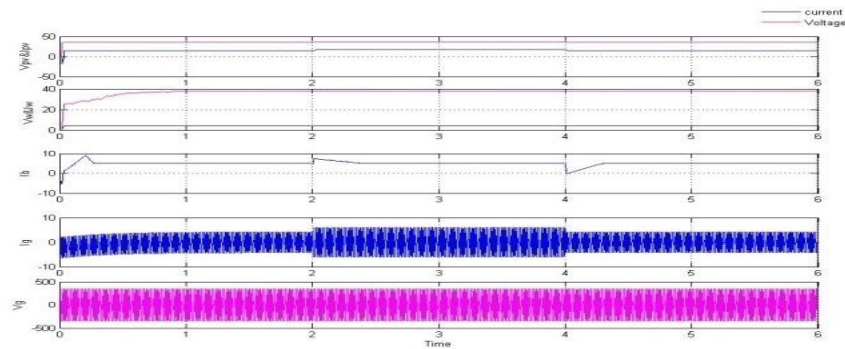

Fig.5. I_{pv} and V_{pv} , I_w and V_w , I_b , I_{grid} and V_{grid} When PV sources increases

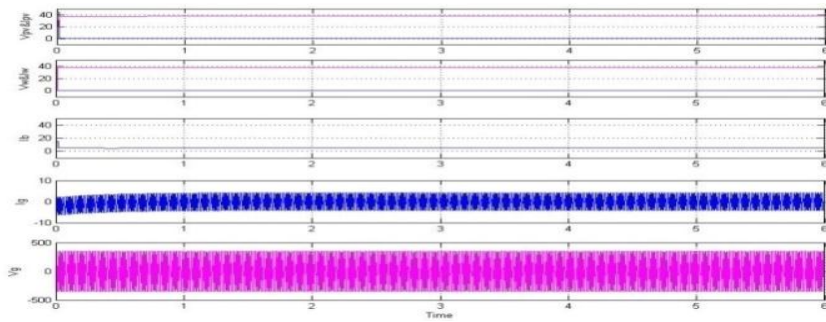

Fig.6. I_{pv} and V_{pv} , I_w and V_w , I_b , I_{grid} and V_{grid} When both PV and wind sources are inactive

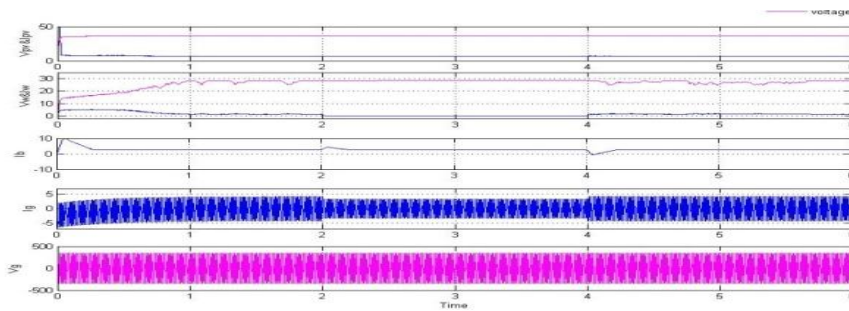

Fig.7. I_{pv} and V_{pv} , I_w and V_w , I_b , I_g and V_g When wind sources decreases suddenly

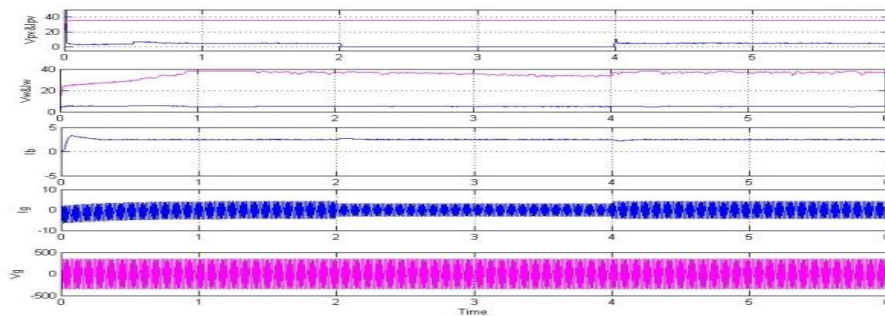

Fig.8. I_{pv} and V_{pv} , I_w and V_w , I_b , I_{grid} and V_{grid} When PV sources decreases suddenly.

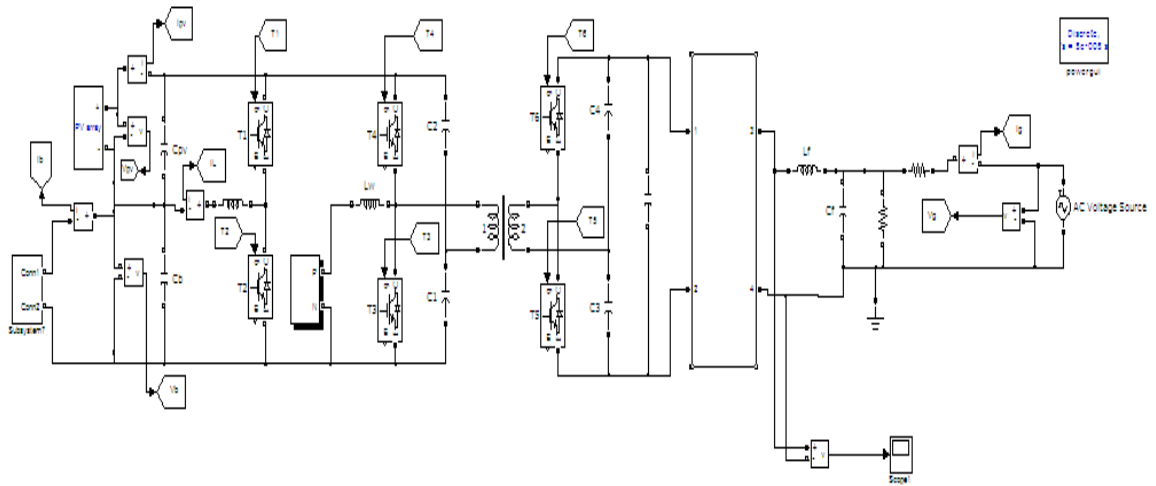

Fig.9. Simulation model for power flow analysis for grid connected DGs with multi 5-level inverter

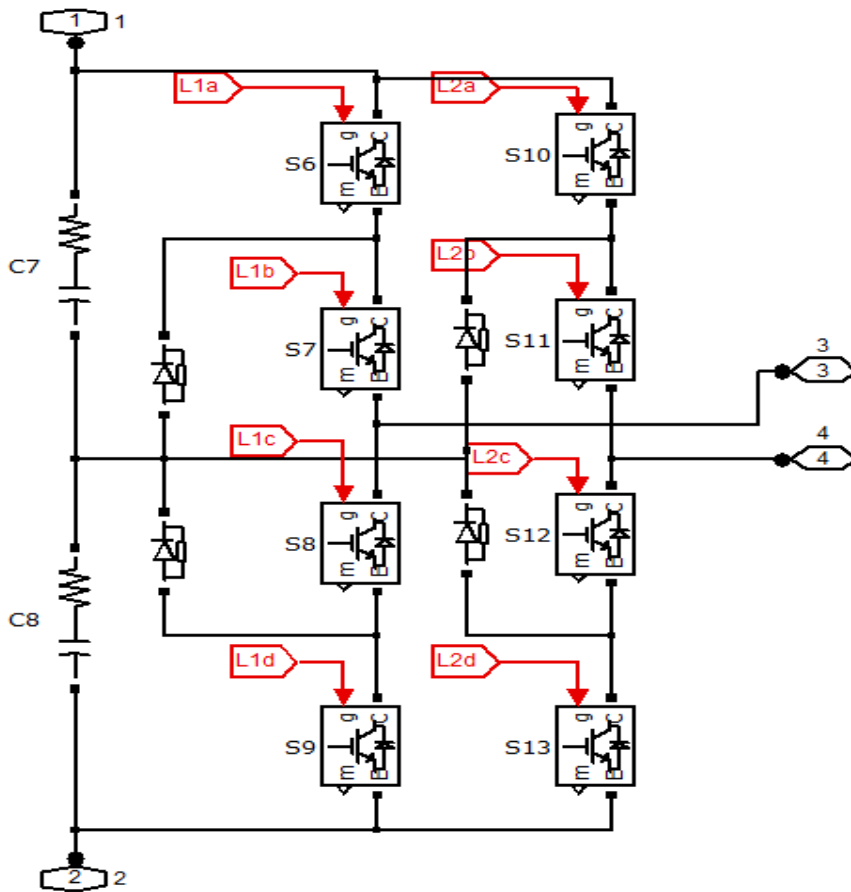

Fig.10.Single phase diode clamped multilevel inverter on the grid side.

VI. THD analysis of PI and multi 5-level inverter

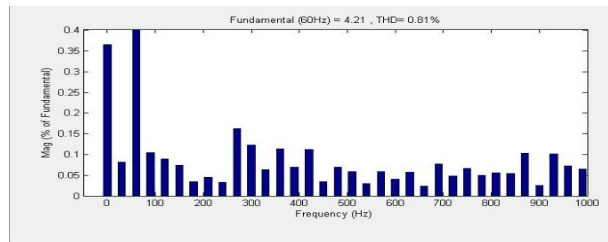

Fig.11.TH D analysis of grid current in PV-Wind inactive mode of operation with PI controller

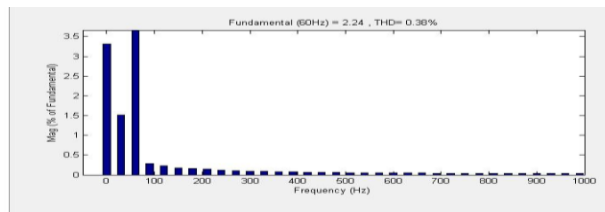

Fig.11.1.TH D analysis of grid current in PV-Wind inactive mode of operation with multi 5-level inverter

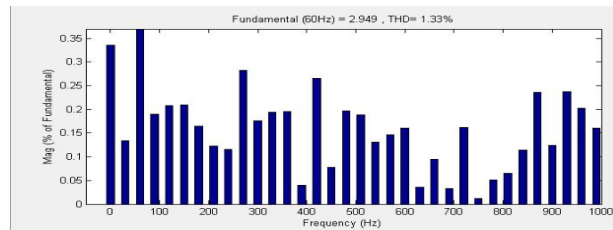

Fig.12.TH D analysis of grid current in PV decreases suddenly mode of operation with PI controller

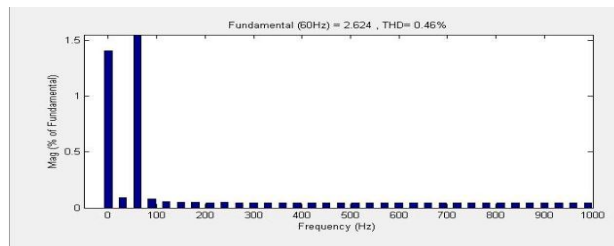

Fig.12.1.TH D analysis of grid current in PV decreases suddenly mode of operation with multi 5-level inverter

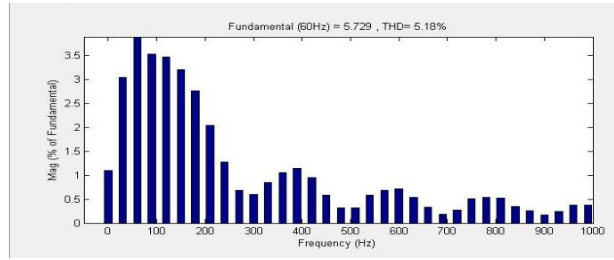

Fig.13.THd analysis of grid current in PV increases suddenly mode of operation with PI controller

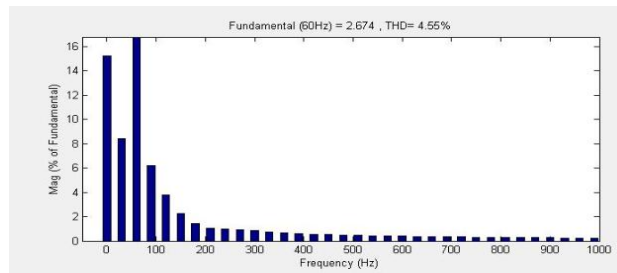

Fig.13.1.THd analysis of grid current in PV increases suddenly mode of operation with multilevel 5-level inverter

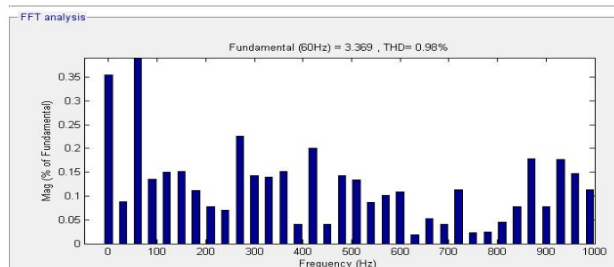

Fig.14.THd analysis of grid current in PV decreases suddenly mode of operation with PI controller

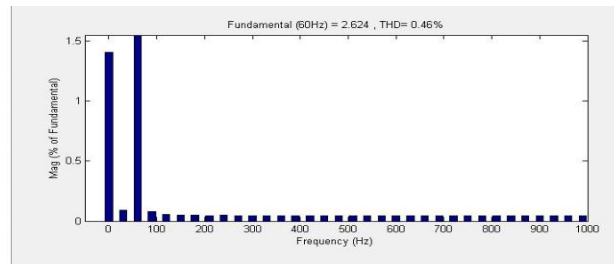

Fig.14.1.THd analysis of grid current in PV decreases suddenly mode of operation with multilevel 5-level inverter

In place of single phase full bridge inverter by connecting a single phase multi 5-level inverter we can reduce the harmonics in grid current and voltage. In this we are used a single phase diode clamped multilevel inverter on the grid side.

We can observe THD analysis in below table

Modes of PV wind operation	Grid current	Grid voltage
PI controller	0.81%	0.10%
Multi 5-level inverter	0.08%	0.09%

CONCLUSION

The longed for crossbreed structure gives an impeccable compromise of Photovoltaic and twist asset to focus most extreme power from the two sources. It is acknowledged by a unique various sources transformer connected double directional dc-dc converter took after in a customary full-connect inverter. An adaptable control procedure will fulfills better use of Photovoltaic, wind control, vitality source limits without influencing presence of battery and power stream organization in a system associated blend photovoltaic-vitality component wind based framework empowering air conditioning molding weights is presented. Distinct recreation studies are finished to take in the attainability of the arrangement, by setting multilevel inverter us spectator the change.

ACKNOWLEDGMENT

We thank to our project guide, Dr. M. Padma Lalitha and N. Sree Ramula Reddy, for providing necessary facilities towards carrying out this work. We are also very much thankful to our project coordinator and entire EEE department faculty in giving the freedom in choosing this project, for continuous support and encouragement.

REFFERANCES

- [1] T. Hirose and H. Matsuo, "Standalone hybrid wind-solar power generation system applying dump power control without dump load," IEEE Trans. Ind. Electron.
- [2] S. A. Daniel and N. A. Gounden, "A novel hybrid isolated generating system based on PV fed inverter-assisted wind-driven induction generators," IEEE Trans. Energy Converters.
- [3] R. Wandhare and V. Agarwal, "Novel integration of a PV-wind energy system with enhanced efficiency," IEEE Trans. Power Electron.

- [4] F. Nejabatkhah, S. Danyali, S. Hosseini, M. Sabahi, and S.Niapour, "Modeling and control of a new three-input DC-DC boost converter for hybrid PV/FC/battery power system," *IEEE Trans. Power Electron.*, vol. 27, no. 5, pp. 2309-2324, Feb. 2014.
- [5] F. Nejabatkhah, S. Danyali, S. Hosseini, M. Sabahi, and S.Niapour, "Modeling and control of a new three-input DC-DC boost converter for hybrid PV/FC/battery power system," *IEEE Trans. Power Electron.*, vol. 27, no. 5, pp. 2309-2324, Feb. 2014.
- [6] Y. M. Chen, C. Cheng, and H. Wu, "Grid-connected hybrid PV / wind power generation system with improved DC bus voltage regulation strategy," in *Proc. of Applied Power Electronics Conference and Exposition, (APEC), Texas*, pp.1088-1094, Mar. 2006.
- [7] Y. M. Chen, Y. C. Liu, S. C. Hung, and C. S. Cheng, "Multi-input inverter for grid-connected hybrid PV/wind power system," *IEEE Trans. Power Electron.*, vol. 22, no. 3, pp. 1070-1077, May 2007.