

## **Design of Controllers in Parametric Based Method for STATCOM Application for Reactive Power Compensation in Linear loads**

**P.K.Behera<sup>\*</sup>, .R.K.Mishra<sup>\*</sup>, M.Pattanaik<sup>\*</sup>, S.S.Sahoo<sup>\*</sup>, P.Prathal<sup>\*</sup>,S.B.Nada<sup>\*</sup> and  
J.K. Moharana<sup>#</sup>**

*#: Professor and Head, \*: Students of 7<sup>th</sup> semester, 2014 Session  
Department of Electrical and Electronics Engineering, GITA, BBSR, Odisha  
Email: jkrushna@rediffmail.com*

### **Abstract**

The STATCOM (STATic synchronous COMpensator) is a shunt connected voltage source converter using self-commutating device and can be effectively used for reactive power control. Its principle of operation is similar to that of a synchronous condenser. This paper describes the modeling of STATCOM along with design of current controller and voltage controller. The design of controllers for the converters can be realized in two ways. The first method is a non-linear realization, which results in simple control rules with faster dynamics. The second method is a linear method, which requires system modeling. The second approach is adopted and simulated waveforms are presented.

**Keywords-** Controller design, PI Controller, STATCOM,

### **I. INTRODUCTION**

Power Electronics Devices are gaining popularity for applications in the field of power transmission and distribution systems. Reactive power (VAR) compensation and control have been recognized [1] as an efficient & economic means of increasing power system transmission capability and voltage stability. The FACTS (Flexible AC Transmission Systems) devices, such as STATCOM have been introduced more recently [2-4]. The controllable reactive power allows for a rapid control of bus voltage and power factor at the system or at the load end. To compensate for the distorted current drawn by the rectifiers from the utility grid, the STATCOM and its current controller must have the capability to track source PWM (Pulse Width Modulation) converters. The linear control is more suitable for STATCOM

application reported in [5-8]. The paper suggests the design of a linear current controller and voltage controller on the basis of gain and time constant adjustment along with the parameter of the coupling inductor and storage capacitor.

The organization of this paper is as follows. The paper initially focuses on the modeling of the STATCOM with the system. Then after current controller and voltage controller are designed. Finally the simulated results are presented with discussion.

## II. MODELING OF STATCOM

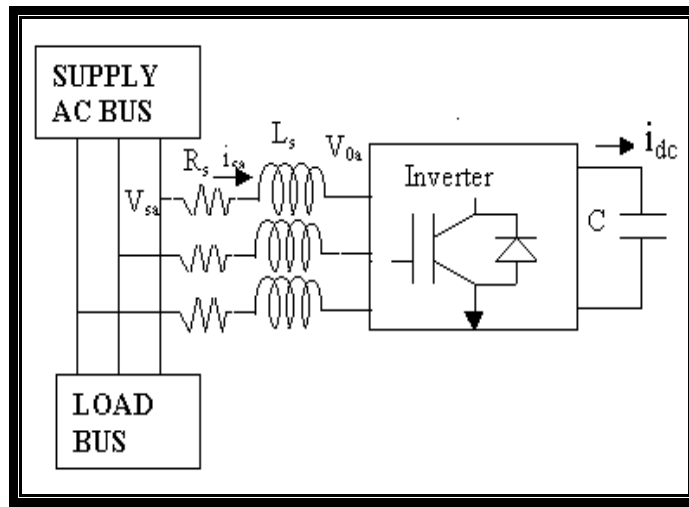

**Fig. 1: Configuration of STATCOM**

The system voltages,  $V_{sa}$ ,  $V_{sb}$  and  $V_{sc}$  are assumed to be sinusoidal and balanced, can be expressed as

$$\begin{bmatrix} V_{sa} \\ V_{sb} \\ V_{sc} \end{bmatrix} = \sqrt{\frac{2}{3}} V_s \begin{bmatrix} \sin(\omega t) \\ \sin(\omega t - \frac{2\pi}{3}) \\ \sin(\omega t + \frac{2\pi}{3}) \end{bmatrix} \quad \text{-----} \quad (1)$$

According to Fig.1, the system currents flowing to STATCOM are shown in (2). The d-q transformation of the ingoing currents and their state space model [5] are shown in (3-4) and (5) respectively.

$$L_s \frac{d}{dt} (i_{abc}) = -R_s i_{abc} + V_{sabc} - V_{0abc} \quad \text{-----} \quad (2)$$

$$L_s \frac{d}{dt} (i_q) = -R_s i_q - \omega L_s i_d + V_{sq} - V_{0q} \quad \text{-----} \quad (3)$$

$$L_s \frac{d}{dt} (i_d) = -R_s i_d + \omega L_s i_q + V_{sd} - V_{0d} \quad \text{-----} \quad (4)$$

$$\frac{d}{dt} \begin{bmatrix} i_q \\ i_d \end{bmatrix} = \begin{bmatrix} -\frac{R_s}{L_s} & -\omega \\ \omega & -\frac{R_s}{L_s} \end{bmatrix} \begin{bmatrix} i_q \\ i_d \end{bmatrix} + \frac{1}{L_s} \begin{bmatrix} V_{sq} \\ V_{sd} \end{bmatrix} - \begin{bmatrix} V_{0q} \\ V_{0d} \end{bmatrix} \quad (5)$$

The equation (5) is a MIMO (Multiple Input Multiple and Output) system and its i/p and o/p are shown in (6)

$$[u] = \begin{bmatrix} V_{0q} \\ V_{0d} \end{bmatrix}, [y] = \begin{bmatrix} i_q \\ i_d \end{bmatrix} \text{ -----} \quad (6)$$

The block diagram of the a.c.side of the STATCOM in d-q transformation as per (5) is shown in Fig.2. The instantaneous voltage of the system and the STATCOM are independent, but the active and the reactive currents are coupled with each other through the reactance of the coupled inductor. So it is very essential to decouple the active and reactive current from each other and design the controller for tracking the required value.

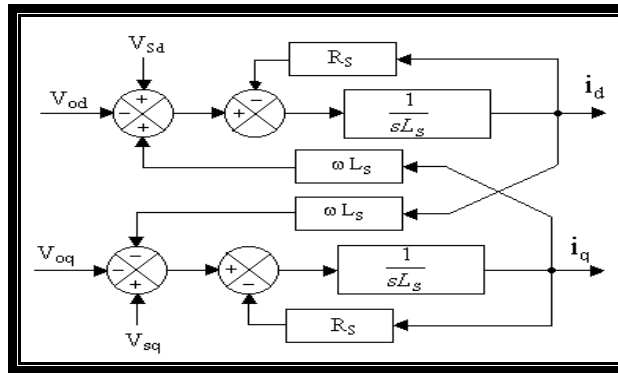

Fig.2: Equivalent Diagram on a.c. side of STATCOM

### III. DESIGN OF CURRENT CONTROLLER.

The controller design for the above system can be done using the strategy [3] attempts to decouple the d and q axes equations, so that the MIMO system reduces to two independent SISO (Single Input Single Output) system. The control inputs  $V_{0d}$  and  $V_{0q}$  are configured as

$$\begin{aligned} V_{0q} &= -V_{0q}^* - \omega L_s i_q + V_{sq} \text{ -----} \\ V_{0d} &= -V_{0d}^* + \omega L_s i_d + V_{sd} \end{aligned} \quad (7)$$

The equation (8) can be obtained by replacing (5) by (7). Hence each row of (8) is independent of each other and thus defines an independent SISO system. Conventional frequency-domain design methods can now be directly applied for current controller. Taking the Laplace transformation of both sides of (8) and rearranging terms are given by (9) and their decoupled SISO system is shown in

Fig.3.

$$\begin{bmatrix} i_q \\ i_d \end{bmatrix} = \begin{bmatrix} -\frac{R_s}{L_s} & 0 \\ 0 & -\frac{R_s}{L_s} \end{bmatrix} \begin{bmatrix} i_q \\ i_d \end{bmatrix} + \frac{1}{L_s} \begin{bmatrix} V_{0q}^* \\ V_{0d}^* \end{bmatrix} \text{ ----} \quad (8)$$

$$G_{q_i}(s) = \frac{I_q(s)}{V_{0q}^*(s)} = \frac{1}{R_s + sL_s}, G_{d_i}(s) = \frac{I_d(s)}{V_{0d}^*(s)} = \frac{1}{R_s + sL_s} \text{ ---} \quad (9)$$

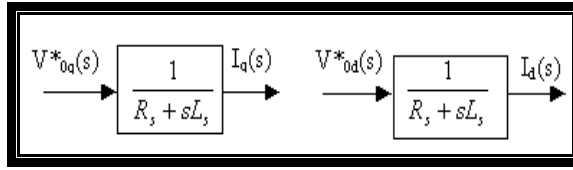
**Fig.3: Current control of inverter of equivalent decoupled SISO systems**

For similar dynamic behaviour of the q and d axis currents, both the q and d axis controllers are identical and its transfer function is given in (10)

$$G_{pi}(s) = \frac{I_q(s)}{V_{0q}^*(s)} = \frac{I_d(s)}{V_{0d}^*(s)} = \frac{1}{R_s + sL_s} \text{ -----} \quad (10)$$

The transfer function of a PI controller is

$$G_{PI}(s) = K \left( 1 + \frac{1}{sT_i} \right) = K_p + \frac{K_I}{s} \text{ -----} \quad (11)$$

With  $K_p = K$ ,  $K_I = \frac{K}{T_i}$ . The transfer function in open loop of PI controller associated with the transfer function on the a.c. system is

$$\left[ G_{pi}(s).G_{PI}(s) \right] = K \left[ 1 + \frac{1}{sT_i} \right] \left[ \frac{1/R_s}{1 + sL_s/R_s} \right] \text{ ----} \quad (12)$$

While taking  $T_i = \frac{L_s}{R_s}$  and simplification which reduces to

$$\left[ G_{pi}(s).G_{PI}(s) \right] = \frac{K}{sL_s} \text{ -----} \quad (13)$$

The closed loop transfer function is

$$\left[ G_{pi}(s).G_{PI}(s) \right] = \frac{1}{1 + s \frac{L_s}{K}} \text{ -----} \quad (14)$$

Thus the system behaves like a first order with an apparent time constant as

$$\tau_a = \frac{L_s}{K} \text{-----} \tag{15}$$

The gain of K can be adjusted such a way that if it is increased too high then the system behaves as second order, otherwise responses very slow. Hence the numerical values for  $K_p$  and  $K_i$  are decided from the circuit parameters,  $L_s$  and  $R_s$  from the required value of K. So the parameters of PI controller are defined as

$$K_p = K, K_i = \frac{KR_s}{L_s} \text{-----} \tag{16}$$

The structure of the effective closed loop system is shown in Fig.4 and is replicated in both the q and d axis current controllers.

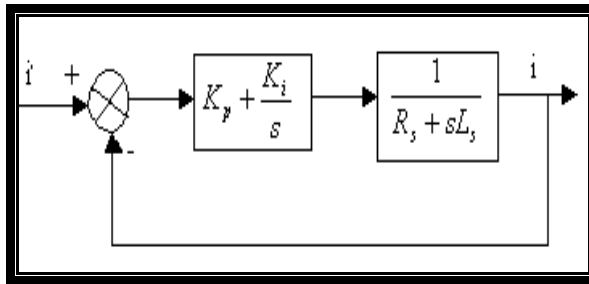

**Fig. 4: Effective closed loop current control system**

**Table-I: Values of the parameters associated to STATCOM**

Meaning	Symbol	Values
Frequency	$f$	50 Hz
Angular frequency	$w$	314 rad/sec
RMS line-to-line voltage	$V_s$	220V
Resistance	$R_s$	1.0 $\Omega$
Coupling inductance	$L_s$	5mH
DC-link capacitor	$C_{dc}$	500 $\mu F$
Modulation index	$m$	0.866
Load resistance	$R_l$	23 $\Omega$
Load inductance	$L_l$	60mH

**IV. DESIGN OF VOLTAGE CONTROLLER**

The switching matrix S of the inverter including the modulation index m is given by

$$S = \begin{bmatrix} S_a \\ S_b \\ S_c \end{bmatrix} = \sqrt{\frac{2}{3}} m \begin{bmatrix} \sin(wt + \alpha) \\ \sin(wt + \alpha - \frac{2\pi}{3}) \\ \sin(wt + \alpha + \frac{2\pi}{3}) \end{bmatrix} \text{-----} \quad (17)$$

In the  $d$ - $q$  frame,

$$\begin{bmatrix} V_{0q} \\ V_{0d} \\ V_{00} \end{bmatrix} = KSV_{dc} = m \begin{bmatrix} \sin \alpha \\ \cos \alpha \\ 0 \end{bmatrix} V_{dc} \text{-----} \quad (18)$$

$$i_{dc} = S^T K^{-1} i_{qd0} = m(i_q \sin \alpha + i_d \cos \alpha) \text{-----} \quad (19)$$

$$m = \frac{\sqrt{V_{0q}^2 + V_{0d}^2}}{V_{dc}}, \alpha = \tan^{-1} \left( \frac{V_{0q}}{V_{0d}} \right) \text{-----} \quad (20)$$

The relation between dc voltage  $V_{dc}$  and current  $i_{dc}$  is

$$V_{dc} = \frac{1}{C} \int i_{dc} dt \text{-----} \quad (21)$$

Let us consider the system voltage and the output of the STATCOM voltage are to be in phase and for unit modulation index, the transfer function can be written as

$$G_{pv}(s) = \frac{V_{dc}}{i_{dc}} = \frac{1}{sC} \text{-----} \quad (22)$$

The transfer function in open loop of PI controller in (11) associated with the transfer function on dc side is

$$\left[ G_{pv}(s).G_{PI}(s) \right]_{ol} = K \left( 1 + \frac{1}{sT_i} \right) \left( \frac{1}{sC} \right) \text{-----} \quad (23)$$

After taking  $T_i=C$  and simplifying

$$\left[ G_{pv}(s).G_{PI}(s) \right]_{ol} = K \left( \frac{1 + sT_i}{s^2 T_i^2} \right) \text{-----} \quad (24)$$

The transfer function in closed loop

$$\left[ G_{pv}(s).G_{PI}(s) \right]_{cl} = \left( \frac{1 + sT_i}{1 + sT_i + \frac{s^2 T_i^2}{K}} \right) \text{-----} \quad (25)$$

So the system behaves like a second order system. As

$T_i \gg \frac{T_i^2}{K}$  and it can be reduced to first order system.

$$\left[ G_{pv}(s).G_{PI}(s) \right]_{cl} = \left( \frac{1}{1 + sT_i} \right) \text{-----} \quad (26)$$

PI controller are defined as

$$K_{pv} = K, K_{iv} = \frac{K}{C} \text{-----} \tag{27}$$

The system parameters are given in Table-I.

PI controller:

For current control,  $K_{pi} = 1, K_{ii} = 200$

For voltage control,  $K_{pv} = 0.1, K_{iv} = 200$

The simulated waveforms of steady and transient outputs of  $i_d, i_q$  and  $V_{dc}$  in capacitive and inductive mode are shown in Fig.5-8.

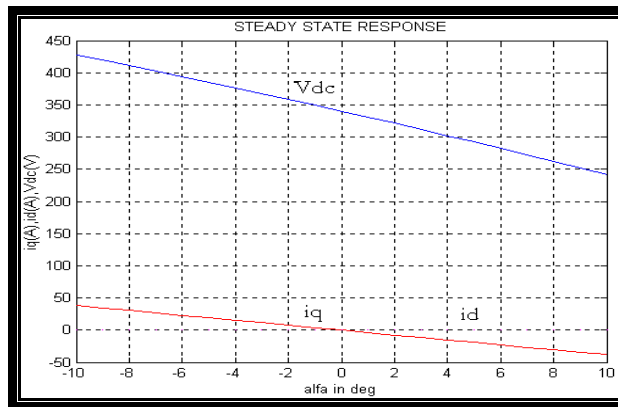

**Fig.5: Steady state response of id and iq**

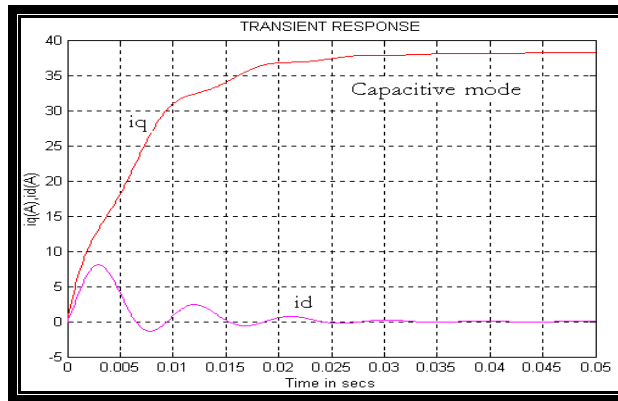

**Fig.6: Transient response of id and iq in capacitive mode**

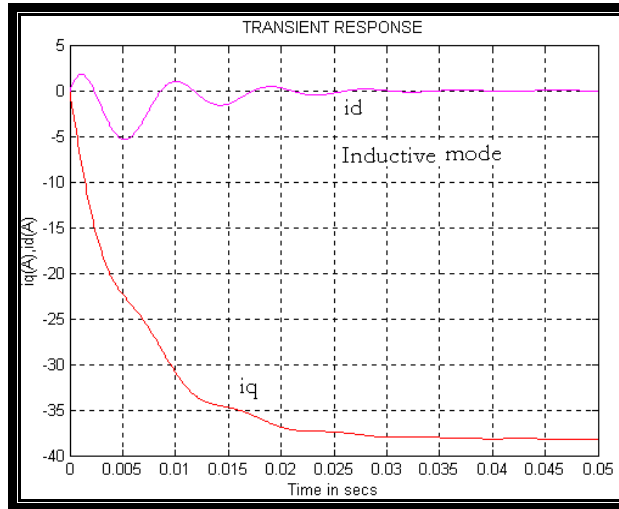

**Fig.7: Transient response of  $i_d$  and  $i_q$  in inductive mode**

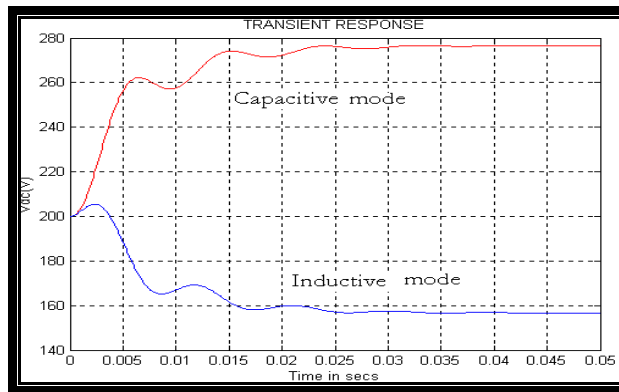

**Fig.8: Transient response of  $V_{dc}$  in both mode**

As per the value of  $i_q$  obtained in steady state and transient, the authors are interested to control the reactive current as per the load. The simulations of the reference reactive current of 15A and reference D.C.voltage of 500V are shown in Fig.9 and 10. These Figs show that the output current and voltage are properly follow the reference values.



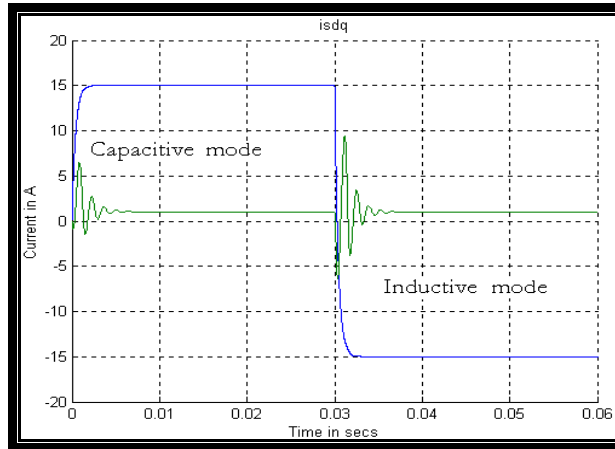

**Fig.9: Current control with reference**

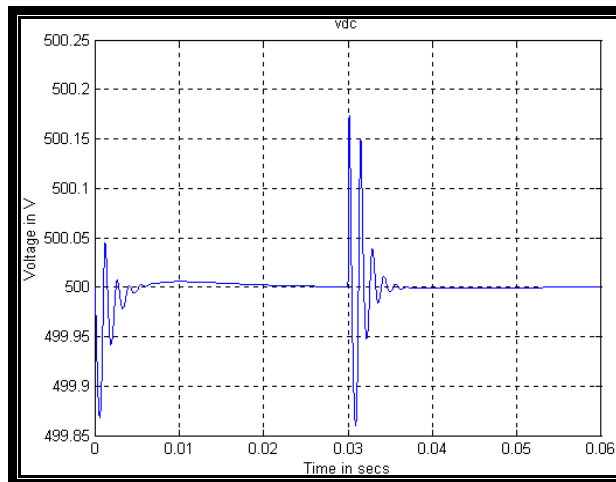

**Fig.10: Voltage Control with reference**

A linear load, simulated with  $R-L$  parameters (given in Table-1, is connected to the Grid. The waveforms of the grid side phase-a voltage ( $v_{sa}$ ) and current ( $i_{sa}$ ) at point of common connection (PCC) (without the STATCOM in operation) are shown in Fig.12. It may be mentioned that here and elsewhere (unless otherwise mentioned)  $v_{sa}$  is plotted to a reduced scale of 10:1. Under steady state it is seen that the power angle is  $39.64^\circ$  (so that power factor is 0.77). The active power and reactive power drawn by the loads and hence supplied by the Grid Station are illustrated in Fig.13. The STATCOM will now act in closed-loop with this system along with the proposed controllers in order to improve this power factor by compensating reactive power. So the PI controllers are applied to control d and q axis current of the STATCOM and DC link voltage. These controllers work well and STATCOM functions in significant manner. The relevant output with proper dynamics is shown in Fig.14 of the system voltage and system current. It is seen that currents Grid phase voltage and current are

in-phase. The Grid is now supplying only active power to the load where load is drawing reactive power from the STATCOM as shown in Fig.15.

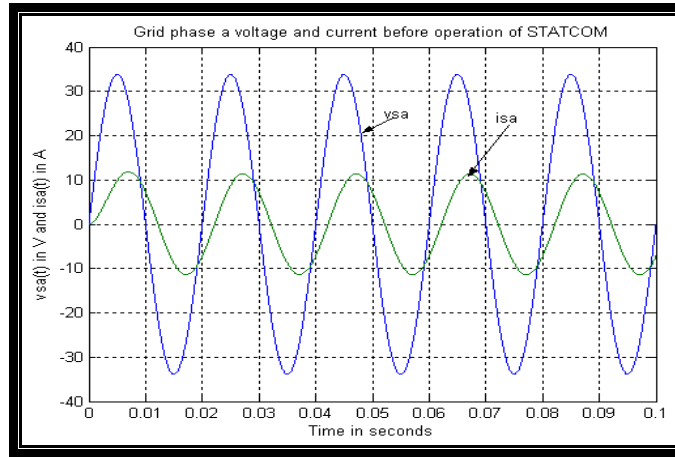

**Fig.12: Grid phase-a voltage and current with  $R - L$  load before operation of the STATCOM**

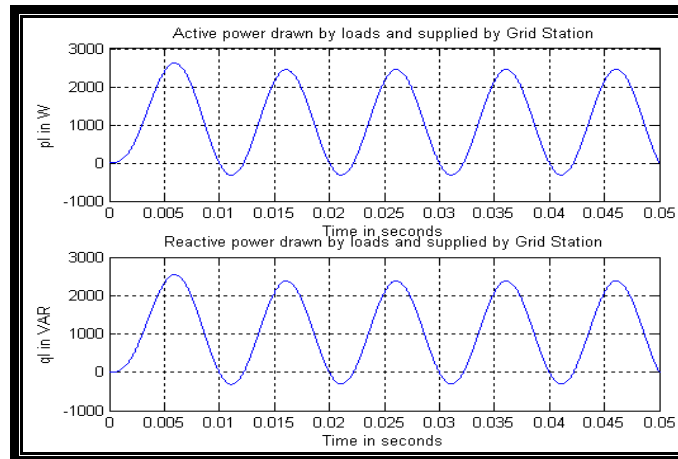

**Fig.13: Grid supplied active and reactive power to  $R - L$  load before operation of the STATCOM**

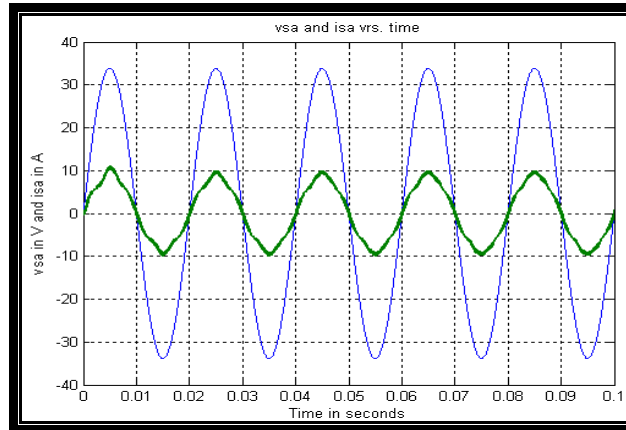

**Fig.14: Grid phase-a voltage and current with  $R-L$  load after operation of the STATCOM**

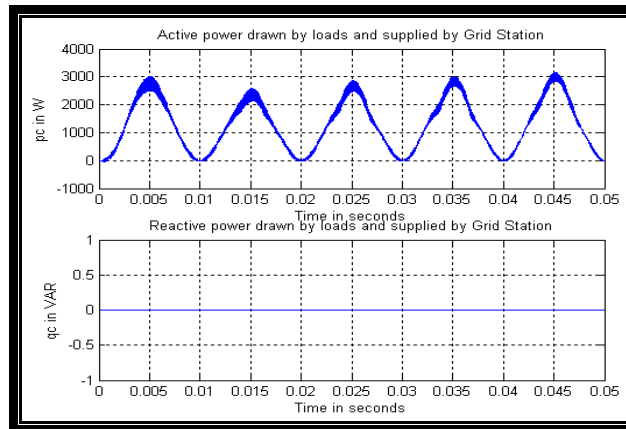

**Fig.15: Grid supplied active and reactive power to  $R-L$  load after operation of the STATCOM**

## V.CONCLUSIONS

The STATCOM is a static replacement of the age-old synchronous condenser. It is connected in shunt to the grid through an ac side reactor. Its principle of operation is similar to that of a synchronous condenser. So, it can be used as power factor compensator. Hence, it is essential to study and analyse the dynamic behaviour of the STATCOM. At the outset, the mathematical model of the STATCOM has been done. This mathematical model is involved in phase angle and modulation index. The open loop characteristics (steady state and transient) of this model have been analyzed. The instantaneous values of the variables ( $i_q, i_d, q_c$  and  $v_{dc}$ ) are not within the limits for a practical set-up of the STATCOM. So, its closed loop control has to be investigated. The complete analysis and models of reactive current and voltage controllers of the STATCOM application are presented. The controllers are designed on the basis of

gain adjustment and time constant. The simulated figures are given which have been controlled the desired values. The linear  $R-L$  loads are simulated and the amount of active with reactive power drawn by the loads from Grid Station is shown in Fig.13. The STATCOM compensates the reactive power not to allow drawing the same from the Grid Station. These outputs have been illustrated in Figs.14 and 15. This is the uniqueness of the STATCOM application.

### ACKNOWLEDGMENT

The authors would like to acknowledge the support received from the department, Principal and BOG members as work is an outcome of project carried in 7<sup>th</sup> semester.

### REFERENCES

- [1] A.T.Johns, A.Ter-Gazarian, and F.Wame, "Flexible AC Transmission Systems (FACTS)" IEE Power and Energy Series, London, U.K.
- [2] D.M.Brod and D.W.Novotny, "Current control of VSI-PWM inverter" IEEE Trans. Industrial Appl, Vol.IA-21, pp.562-570, July/Aug.1985.
- [3] S.Busso, L.Malesani and P.Mattavelli, "Comparison of Current Control Techniques for Active Filter Application" IEEE Trans. Industrial Electronics, Vol.45, No.5, pp.722-729, October 1998.
- [4] C. Shauder and H.Mehta, "Vector Analysis and Control of Advanced Static VAR Compensators", IEE Proc, 140, No.4, pp.299-306 July 1993.
- [5] Sengupta, M., Moharana, J.K., Sengupta, A " Study on an Advanced Static VAR Compensator switched from a Space Vector PWM inverter –Analysis, simulation and comparison with the conventional sinusoidal PWM, NPEC 2003, IIT Bombay, 16-17 Oct 03 pp 72-78
- [6] A. Draou, M. Benghanem and A. Tahiri, "Multilevel Converter and VAR Compensation", Power Electronics Handbook", pp.599-611, Academic Press, 2001.
- [7] M.Sengupta J.K Moharana and A.Sengupta, " Study on an Advanced Static VAR Compensator switched from a Space Vector PWM inverter –Analysis, simulation and comparison with the conventional sinusoidal PWM, NPEC 2003, IIT Bombay, 16-17 Oct 03 pp 72-78.
- [8] G.C.Cho, N.S.choi, C.T.Rim, and G.H.Cho, "Modeling, Analysis and Control of STATIC VAR Compensator using three level inverter", IEEE, Ind.Society, Annual Meet, page 837-843, 1992