

## **Designing and Optimization of Inset Fed Rectangular Microstrip Patch Antenna (RMPA) for Varying Inset Gap and Inset Length**

**Vinayak Samarthay<sup>1</sup>, Swarna Pundir<sup>2</sup>, Bansi Lal<sup>3</sup>**

<sup>1,3</sup> *Deenbandhu Chhotu Ram University of Science and Technology,  
50<sup>th</sup> K. M. Stone, N. H. 1, Murthal (Sonapat) Haryana*

<sup>2</sup> *Rajasthan Technical University | Rawatbhata Road, Kota-324010*

### **ABSTRACT**

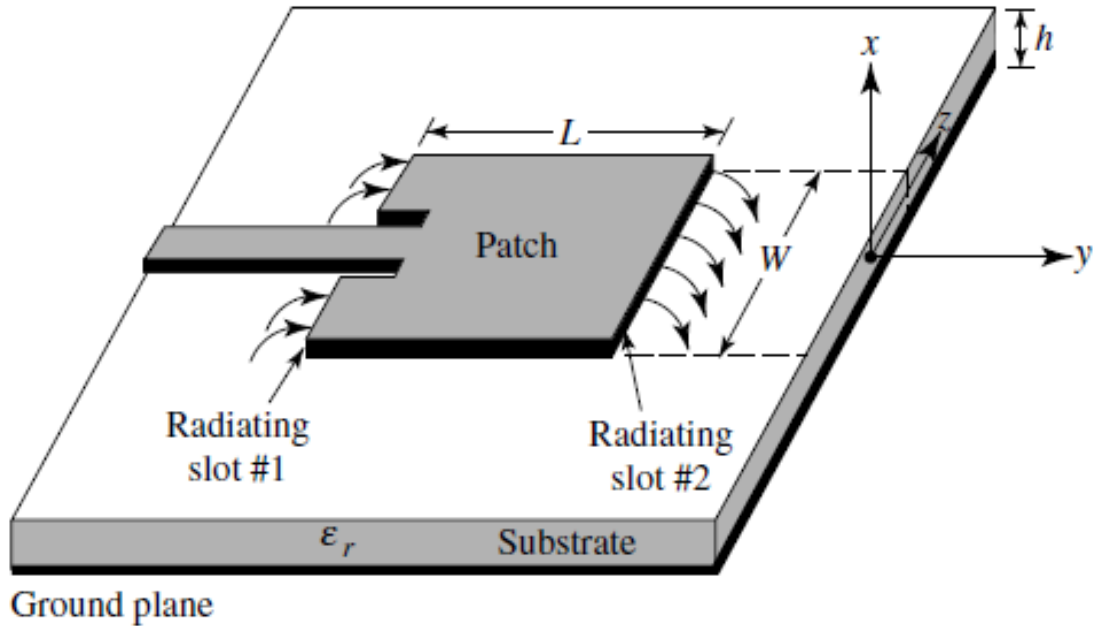
This paper investigate the dependency of antenna parameters designed for 10 GHz inset fed rectangular micro strip patch antenna (RMPA), on varying inset width and inset gap for proper impedance matching so as to have minimum return loss and achieve efficient operation. Here we are analyzing as well as comparing the variation in parameters by varying both the inset gap (Y-axis) and inset length (X-axis). It has been observed that the performance of patch antenna depends more on inset gap between patch conductor and inset fed line rather than inset length. The simulated result also shows that the proposed antenna design has a good bandwidth (BW) antenna efficiency, radiation efficiency, directivity and gain.

**KEY WORDS:** RMPA, Inset fed, Dielectric Constant, Return loss.

### **1. INTRODUCTION-**

Micro strip patch antenna has drawn attention of researchers over the last decade due to their Low profile, light weight, low cost and ease of integration with printed technology. They have a wide range of applications from cell phones to life saving biomedical applications. The research on patch antenna basically demands size reduction, wide bandwidth, increasing gain and system level integration. Though some of the antenna parameters are more likely to depend upon the geometry of antenna, type of feed, substrate materials height and dielectric constant. Inset fed antenna has the advantage of having the simplest to implement and easy to study the behavior of basic patch antenna where the properties of antenna can be easily controlled by the inset gap and inset length. The inset-fed micro strip antenna provides a method of impedance control with a planar feed configuration [1-2]. The

experimental and numerical results showed that the input impedance of an inset-fed rectangular patch varied as a  $\text{Cos}^4$  function of the normalized inset depth [1]. A more recent study proposed a modified shifted  $\text{Sin}^2$  form that well characterizes probe-fed patches with a notch [3]. It is found that a shifted  $\text{Cos}^2$  function works well for the inset-fed patch [4][5].



**Fig 1:** Radiation Mechanism for Microstrip Patch Antenna

## 2. DESIGN PROCEDURE FOR PATCH

While adopting the design strategy we try to keep the return loss as minimum as possible. Design procedure is conventional based on existing literature, choosing  $\epsilon_r$  in advance as dielectric of substrate are not easily available which alongside also brings the thickness of the material with itself.

Steps Involved :

### 1. Calculate Width 'W' [4]

$$W_p = \frac{C}{2f_r} \sqrt{\frac{2}{\epsilon_r + 1}} \quad \text{Eq. 1}$$

### 2. Calculate $\epsilon_{\text{reff}}$ [6]

$$\epsilon_{\text{reff}} = \frac{\epsilon_r + 1}{2} + \frac{\epsilon_r - 1}{2} \left[ 1 + 12 \frac{h}{W_p} \right]^{-1/2} \quad \text{for } W_p/h > 1 \quad \text{Eq. 2}$$

**3. Calculate  $\Delta L$  i. e. normalized length [5]**

$$\frac{\Delta L}{h} = 0.412 \frac{(\epsilon_{\text{reff}} + 0.3) \left(\frac{W_P}{h} + 0.264\right)}{(\epsilon_{\text{reff}} - 0.258) \left(\frac{W_P}{h} + 0.8\right)} \tag{Eq. 3}$$

**4. Calculate  $L$**

$$L_P = \frac{v_0}{2f_r \sqrt{\epsilon_{\text{reff}}}} - 2\Delta L \tag{Eq. 4}$$

**5. Calculating  $Z_0$  [7, 8]**

$$Z_0 = R_{in} \cos^2 \left( \frac{\pi}{L_P} - d \right) \tag{Eq. 5}$$

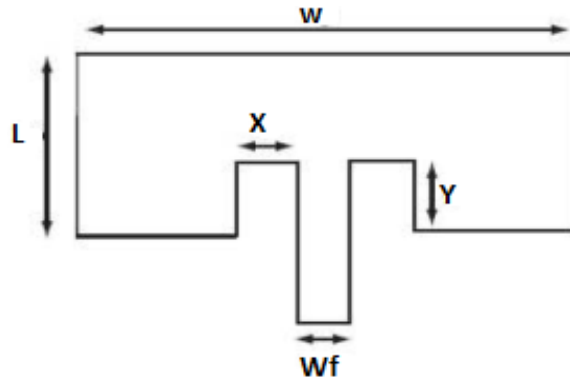
Tabulated values using above equations are shown in Table 1.

**Table 1:** Physical Dimensions of Microstrip patch Antenna

Operating frequency	10 GHz
Dielectric Constant	4.4 (FR-4)
Length of the patch L	6.48 mm
Width of the patch W	9.128 mm
Thickness ( $t$ ) of the Substrate	1.5mm
Model for Analysis	Transmission Line TLM
Substrate Length	15.48 mm
Substrate Width	18.12mm

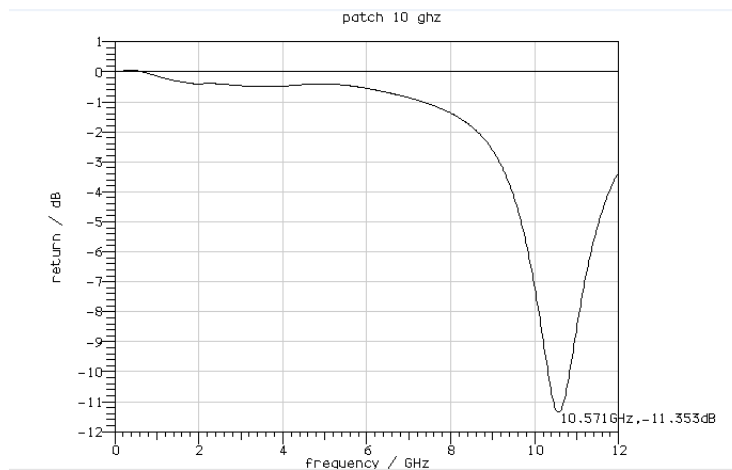
**Table 2.** Iteration Results for RMPA using Different Inset Length and Inset Width

Iteration Patch No.	Inset Gap X (mm)	Inset Length Y (mm)	Resonance Frequency ( $f_r$ ) (GHz)	Return Loss S11 (dB)	Antenna Efficiency (%)	Radiation Efficiency (%)	Directivity (dbi)	Gain (dbi)	Bandwidth (%)
1	0	0	10.571	-11.353	80.216%	99.150%	6.553	5.595	4.9
2	0.3	0.2	10.634	-11.555	78.634%	99.133%	6.565	5.521	5.3
3	0.4	0.2	10.646	-11.778	78.330%	99.129%	6.566	5.505	5.5
4	0.5	0.2	10.664	-11.996	77.814%	99.122%	6.566	5.477	5.8
5	0.6	0.2	10.683	-12.328	77.133%	99.118%	6.566	5.439	6.1
6	0.7	0.2	10.698	-12.654	76.773%	99.113%	6.566	5.418	6.5
7	0.8	0.2	10.796	-15.065	72.921%	99.109%	6.568	5.197	6.5
8	0.9	0.2	10.783	-14.672	73.713%	99.108%	6.559	5.235	6.8
9	0.3	0.3	10.675	-12.550	77.175%	99.124%	6.569	5.443	6.3
10	1	1	10.850	-19.081	69.497%	99.099%	6.563	4.983	7.6
11	1.5	0.5	10.782	-17.887	72.637%	99.050%	6.569	5.180	7.5
12	5.7	0.2	9.711	-20.482	91.007%	98.905%	6.592	6.183	6.3
13	6	0.2	9.650	-30.159	91.422%	98.980%	6.585	6.196	7.7

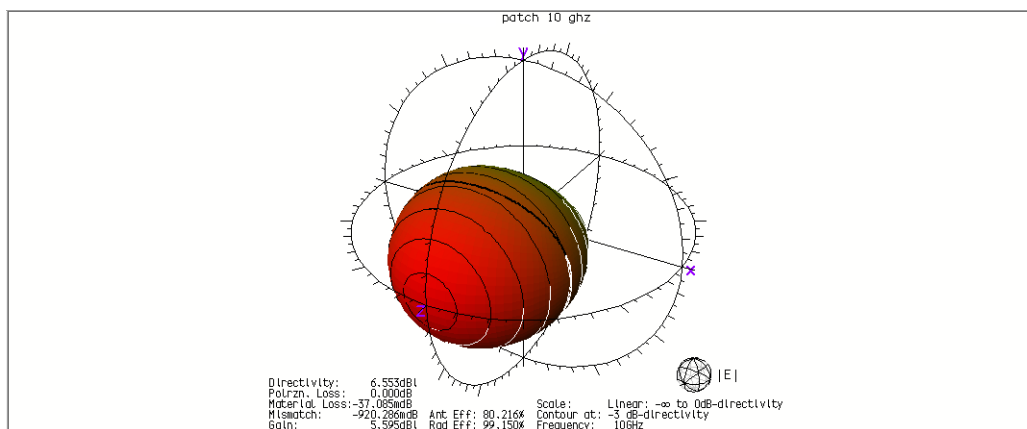


**Fig. 2:** Dimensional Layout for Proposed Antenna

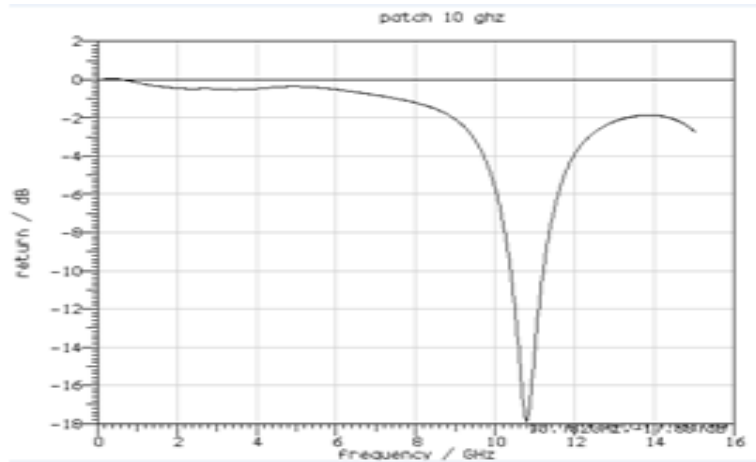
**4. Graphical Representation for different Iteration of Patch**



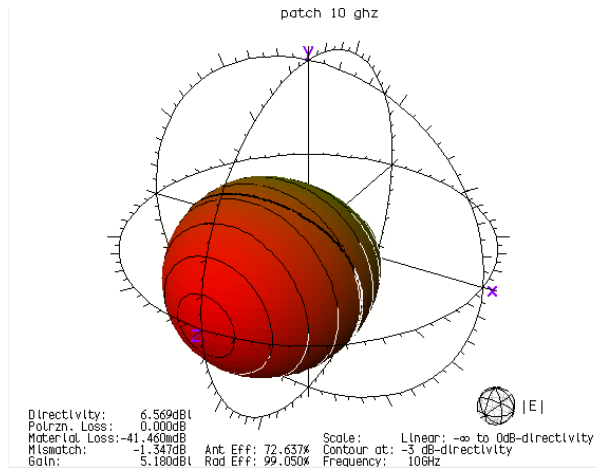
**Fig. 3:** Return Loss for Patch 1



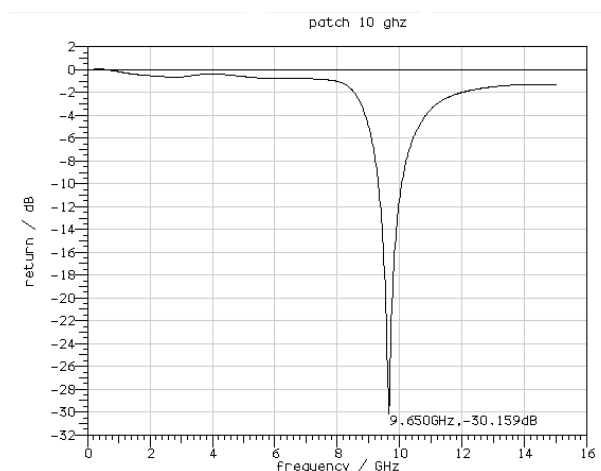
**Fig. 4:** Radiation pattern for Patch 1



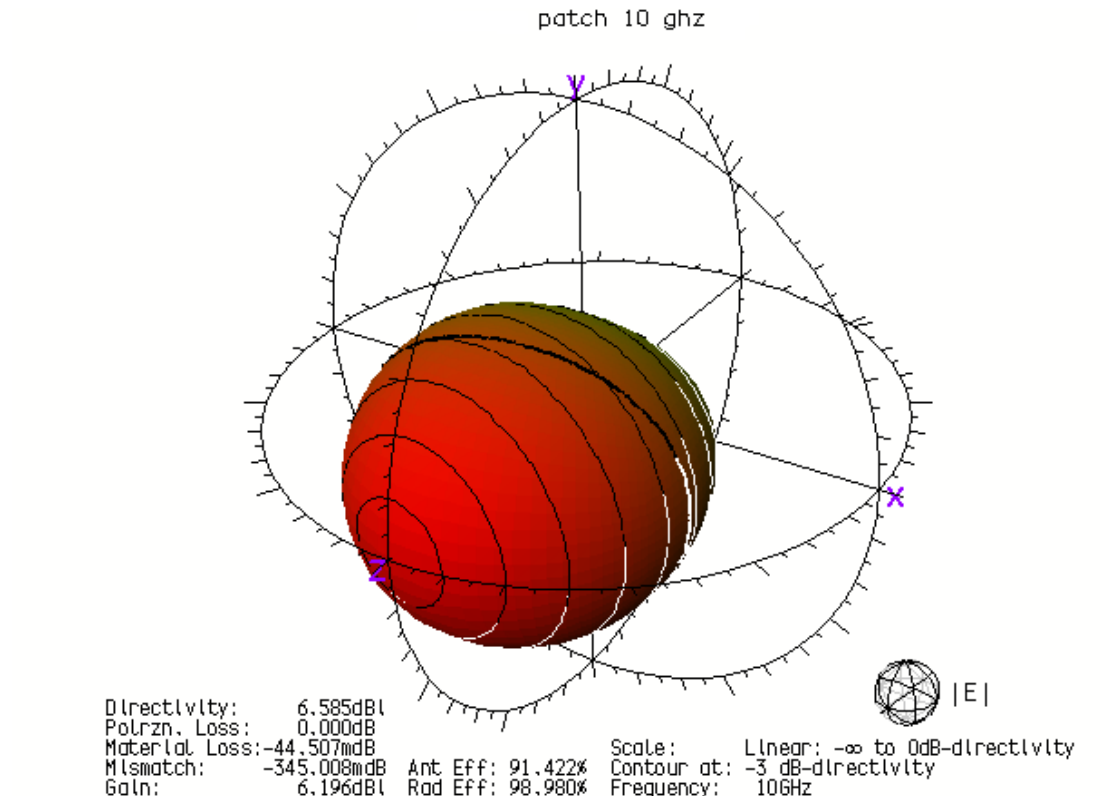
**Fig. 5:** Return Loss for Patch 11



**Fig. 6:** Radiation pattern for Patch 11



**Fig. 7:** Return Loss for Patch 13



**Fig. 8:** Radiation pattern for Patch 13

### Results and Conclusions

Here keeping inset fed width ( $W_f$ ) to 1 mm, we increased the inset gap ( $X$ ) while keeping inset length ( $Y$ ) constant. We can easily analyze that with increasing inset gap increases return loss of the patch as well as gain, radiation, antenna efficiency and bandwidth. A slight change in inset length with respect to inset gap also changes the overall performance of the patch antenna. It can be easily concluded that the effect of varying inset gap has more pronounced effect on parameters of antenna as compared to the inset length.

### REFERENCES

- [1] L. I. Basilio, M. A. Khayat, J. T. Williams and S. A. Long, "The Dependence of the Input Impedance on Feed Position of Probe and Microstrip Line-fed Patch Antennas," *IEEE Trans. Antennas and Propagation*, Vol. AP-49, pp. 45-47, Jan. 2001.
- [2] T. Samaras, A. Kouloglou, and J. N. Sahalos, "A note on the impedance variation with feed position of a rectangular microstrip antenna," *IEEE Antennas and Propagation Magazine*, Vol. 46, pp. 90-92, April 2004.
- [3] Y. Hu, E. J. Lundgren, D. R. Jackson, J. T. Williams, and S. A. Long, "A Study

- of the Input Impedance of the Inset-Fed Rectangular Microstrip Antenna as a Function of Notch Depth and Width, " 2005 AP-S International Symposium, Washington DC, July 2005.
- [4] I. J Bahl and P Bhartia, *Microstrip Antenna*, Artech House, Dedham. M. A, 1980.
  - [5] T. A. Milligan, *Modern Antenna Design*, McGraw-Hill Book Co., New York, 1985
  - [6] C. A. Balanis, *Advanced Engineering Electromagnetics*, John Wiley & Sons, New York, 1989
  - [7] A. G. Derneryd, "A Theoretical Investigation of the Rectangular Microstrip Antenna Element, "IEEE Trans. Antenna Propagat., Vol. AP-26, No. 4, pp532-535, July1978
  - [8] K. R. Carver and J. W. Mink, "Microstrip Antenna Technology, "IEEE Trans. Antenna Propagat., Vol. AP-29, No. 1, pp2-24, Jan 1981.