

A Study to Improve the Efficiency and Performance of a Pelton Wheel using Potential Energy at Low Heads

J.M.Hlabanelo *¹, P.B Sob², A.A Alugongo³

^{1,2,3}*Department of Mechanical Engineering, Faculty of Engineering and Technology, Vaal University of Technology, Vanderbijlpark 1900, Private Bag X021, South Africa.*

²*ORCID: 0000-0002-1796-7694*

Abstract

Most often the Pelton wheel is only efficient or stable in power generation when working at very high heads. This has resulted to low generation of electric energy during summer or dry season in most Countries that use hydroelectric generation plant. With the current climate change, it is likely that this problem will become worst in dry season and energy generation will become more unstable. This will lead to other source of energy such as nuclear and thermal plants that has their own challenges in climate change. Since hydroelectricity is a clean source of energy research efforts should geared more on improving the efficiency and power generated by hydroelectric system. In the current study we have designed a new Pelton wheel impulse turbine using potential energy at very low heads. The design was tested and the produced power and efficiency during operation were measured. The new designed system was powered using a pump to provide the artificial low heads. The designed Pelton-wheel impulse turbine at low heads transforms gravity energy of elevated water into mechanical work, which changed into electrical energy for domestic and industrial application. In the current study the tool of stochastic mechanics and fluid dynamics were used to modeled the theoretically phenomena during kinetic and potential energy delivered by the water to the-jet and the buckets of the Pelton-wheel. Their random behavior were analyzed theoretically and validated experimentally using ANSYS and Inventor stress analysis to analyses the stresses Equivalent (von-Mises) Stress and Total Deformation. The following facts were revealed and validated experimentally. Significant gain of energy was observed with increased in electrical efficiency when the number of jets and buckets increases at low energy head of water supplied. The developed system was more efficient for low-head and heavy discharge applications. For the same head condition, heavy electrical generators can be used for the modified gravitational Pelton-wheel than the conventional Pelton-wheel which can boast power generation at very low head. It was also observed that the energy in the runner shaft is lower in the conventional Pelton wheel during operation. It was also shown that the modified system was more efficient than the conventional impulse and reaction turbines. It was also revealed that the modified Pelton wheel can operate at low-head and can be used in heavy-discharge applications using considerable amount of potential energy with the kinetic energy.

Keywords: Efficiency, performance, Pelton wheel, potential energy and low head

INTRODUCTION

We do not need a rocket scientist, an engineer, scientist, or a researcher to alert us about the current electricity energy challenges especially in South Africa and other African countries due to climate change that imminent to energy crisis [1-12]. Most often the available source of energy has several environmental implications such as pollution and destruction of the ozone layer which has led to global warming and climate change [1-7]. The foremost causes of the imminent energy crisis are polluted energies in form of toxic gases that are been released from different kind of sources chemical industries, manufacturing industries, fuels, vehicles, aero planes and refrigerators from our homes [1-6]. Most of these alternates such of energy have several environmental pollutions and the cleanest source of energy such as hydro electric energy and solar are having a serious problem of low efficiency specifically in raining season [10]. This has resulted to low generation of electric energy during summer or dry season in most Countries that use hydroelectric generation plant. With the current climate change, it is likely that this problem will become worst in dry season and energy generation will become more unstable [1-11]. From the research and through feasibility studies Pelton wheel is only efficient or stable in power generation when working at very high heads. This has resulted to low generation of electric energy during summer or dry season in most Countries that use hydroelectric generation plant.

In the current study we have designed a new Pelton wheel impulse turbine using potential energy at very low heads. The design was tested and the produced power and efficiency during operation were measured. The new designed system was powered using a pump to provide the artificial low heads. The new design is functioning in the way it can be less costly compared to commercial known Pelton Wheel Turbine were its operated at high heads and low discharge, new design it's an contrary to usual one as we use low heads and high discharge with this rate, we can use low heads to generate electricity. Efficiency is the main factor that must always reach the optimum target to achieve what is required by the manufacture and demand needed. Electric power plant efficiency η is

defined as the ratio between the useful electricity output from the generating unit, in a specific time, and the energy value of the energy source supplied to the unit in the same time period.

So, it can be said that to get high efficiency, the turbine is needed to be operated in high discharge applications. Improved gearing arrangement & larger buckets could give better efficiency as well. It can be recommended to minimize the inertial losses to increase the efficiency. Pelton turbines are not used at lower heads because their rotational speeds become very slow and the runner required is very large and bulky. If runner size and low speed do not pose a problem for a particular installation, then a Pelton turbine can be used efficiently with fairly low heads. If a higher running speed and smaller runner are required, then there are two further options are available such as increasing the number of jets and using twin runners as proposed in this study. The Pelton wheel is generally used for high head and low discharge applications. But it can be used for the low head also by adding some modifications in design as proposed in this study. Splitters are used to increase the efficiency of the outlet of the water jet so that water can leave the bucket with a minimum velocity which is theoretically assumed tends to zero as proposed in this study. The special

modification is to increase the depth of the buckets which is not done in the usual Pelton wheel buckets. In case of conventional Pelton wheel, only energy of the jet impinged from the nozzle, is used but there is no application of gravity in the turbine action. In this gravitational low head Pelton wheel, both the kinetic and gravitational energy of the jet are used during operation. The weight of this stored water per second in the bucket is the amount of potential energy per second from water jet.

The purpose of this venture plan is to plan a show Pelton-wheel turbine utilizing potential vitality at low heads and overwhelming release, with was supported by the structural compliance of SABS 0162 Basic steel code in the design process. This enhanced the mechanical stability and productivity of the designed Pelton wheel at a weight of 1Mpa of the pump, with a runner breadth 220mm, 14 buckets, spout distance across 8mm and shaft 20 mm breadth with 450mm long. Therefore, in the current study, a new Pelton wheel design was developed after modifying a Lo Head Potential energy. In the research Four (4) Sub-Problems were addressed during the modification process. The sub problems are,

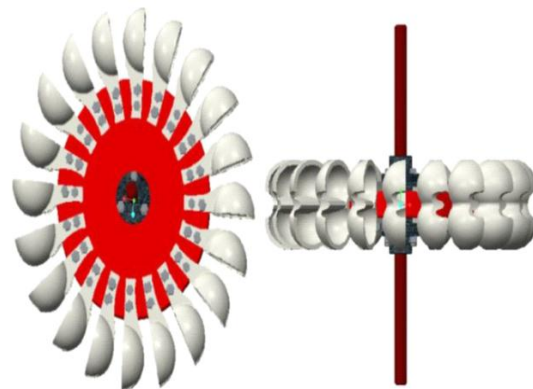

Figure 1: Photograph of model design Pelton wheel turbine

- **Statement of sub-problem 1/Aim 1**
 - ✓ To Design the Pelton wheel runner with total Diameter of 220 mm, thickness of 10mm as well 21 buckets with total hub width 54 mm, outspread length 36 mm, depth 18.4 mm.
- **Statement of sub-problem 2/Aim 2**
 - ✓ To install the Mono pump 22M that will create an artificial head with a Pressure of 1000 kPa, speed of 1450 r/min, minimum starting torque 7, 5 Nm and rotation is dual.
- **Statement of sub-problem 3/Aim 3**
 - ✓ To design nozzle of the jet with total jet diameter 21 mm, jet ratio(m) 12.8 and 2 jets to rotate pelton wheel
- **Statement of sub-problem 4/Aim 4**
 - ✓ To design a Pelton wheel shaft with the total diameter of 110 mm and 1000mm long that will rotate runner and buckets coupled to the alternator.

Pelton wheel turbines are not utilized at lower heads since their rotational speeds ended up exceptionally gradually and the runner required is exceptionally huge and bulky [1-7]. So it's concludes that regularly Pelton wheel is for the most part utilized for (High heads) and (Low release) applications. But it can be utilized for the (Low heads) too by including a few adjustments in plan which leads to the modification of the current design. From the above statement it could be seem logical to conclude that they should be a direct relationship in terms heads elevation and discharge performance of the Pelton Wheel turbine variations. The runner could be a circular plate mounted on the pivoting shaft or rotor. This circular circle has glass formed edges, called as buckets, put at rise to dispersing around its circumference. The buckets are appropriately moulded to get the water without a stun. The runner is connected to coupling centre that's keyed to the shaft which is even. The runner is made of Bakelite. Runner breadth choice is related with the speed of water affecting the runner, which is straightforwardly related to accessible head. The higher the head, the littler the runner breadth for a given steady shaft

speed. Beneath perfect conditions, the runner speed is roughly half the water jet velocity. For common sense, runners for littler turbines are more often than not constrained to fair a number of.



Figure 2: The photography of Pelton wheel turbine coupled to shaft mounted of top a casing in the study

Furthermore, this potential energy is converted into kinetic energy as this water filled bucket freely (assumed) falls. It is also possible to extract kinetic energy from the penstock nozzle discharge by means of a jet strike on the conventional Pelton-wheel vanes of the runner. This hydro system is good for a low-head and heavy-discharge application. Apart from this, gravitational energy of stored water is further extracted during emptying of bucket water by means of jet-propulsion under water head. This jet propulsion works on a runner wheel taking place due to the Gravitational-Force on bucket's stored water and results in a water jet discharge. A Pelton wheel is for the most part utilized for (High heads) and (Low release) applications. But it can be utilized for the (Low heads) and (High release) applications too by including a few alterations in plan. This sort of free-jet water turbine is to begin with presented by an American design named Lester Pelton in 1870 which has undergone several modifications to improve the system efficiency [1-11].



Figure 3: The photography of Pelton wheel turbine mounted on top of a casing

METHODOLOGY

Theoretical Framework for Model Pelton Wheel using Potential Energy at Low Heads Design

In deriving the theoretical model for the application to improve the Efficiency and Performance of a Pelton Wheel using Potential Energy at Low Heads. It is one of the major types of turbines, along with reaction turbines. Impulse turbines operate based on the concept of velocity, namely by changing the direction of a jet of either fluid or gas. This impulse in turn rotates the turbine and creates energy. A turbine that is driven by high velocity jets of water or steam from a nozzle directed on to vanes or buckets attached to a wheel. The resulting impulse (as described by Newton's second law of motion) spins the turbine and removes kinetic energy from the fluid flow. Before reaching the turbine, the fluid's pressure head is changed to velocity head by accelerating the fluid through a nozzle. This preparation of the fluid jet means that no pressure casing is needed around an impulse turbine.

The conduit bringing high-pressure water to the impulse wheel is called the penstock. This was strictly just the name of the valve, but the term has been extended to the conduit and its appurtenances as well, and is a general term for a water passage and control that is under pressure, whether it serves an impulse turbine or not. The Pelton-wheel impulse turbine model is a device that transforms gravity energy of raised water into mechanical work, which can be changed over into electrical energy utilizing an electrical alternator. The dynamic energy delivered by the waterjet is coordinated extraneously to the buckets of the Pelton-wheel. A Pelton wheel is for the most part utilized for (High heads) and (Low release) applications. But it can be utilized for the (Low heads) and (High release) applications too by including a few alterations in plan. This sort of free-jet water turbine is to begin with presented by an American design named Lester Pelton in 1870. Afterwards, the buckets were modified to split buckets in 1880 which are now universally used to produce power. The objective of this inquire about is to plan a Pelton wheel for getting most extreme productivity for all parameters. These parameters are turbine particular productivity, number of buckets required, number of planes and the measurement of fly, spout measurement, turbine control, torque, runner speed, bucket measurement and amid different conditions. The speed of runner is altering by Primary one is to alter the release as well as the fly speed and the moment on is the adjustment within the runner.

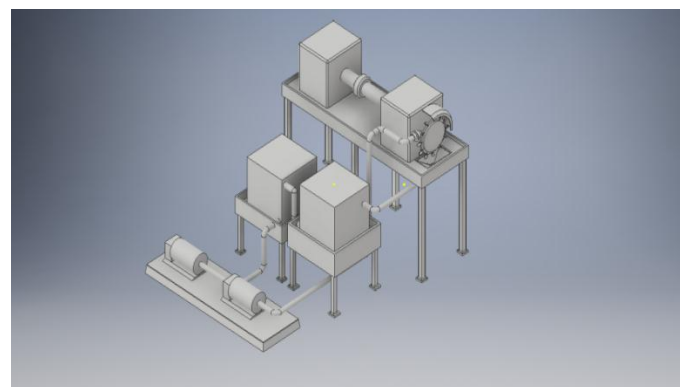

Figure 4: Photograph of complete project design

A Pelton wheel is an impulse turbine that has at least one free jet. The jets release water into an aerated space where it is caught by a series of buckets or cups located on the runner, the rotating piece of the turbine that is used to convert the water's energy into mechanical energy. Typically, these buckets are divided into two sections so they are able to deflect water away from the oncoming jets. A Pelton wheel also has a cutaway on the lower lips of the buckets, which allows a subsequent bucket to move ahead before it stops the water jet that has moved the previous bucket. As a result, the buckets enter the water jet

more smoothly.

WORKING PRINCIPLE OF PELTON TURBINE

The water from the tank flows through a pipes which contains an orifice at the outlet. The nozzle escalates the kinetic energy of the penstock water. At the outlet this nozzle produces a water-jet.

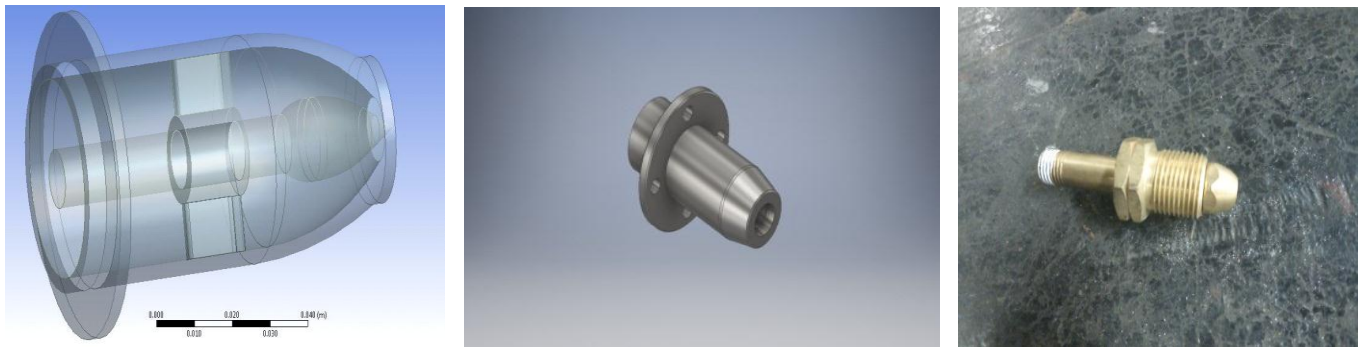

Figure 5: Schematic Photographs of nozzles for the jet nozzle

This water-jet strikes on buckets of the runner and transfers its kinetic energy to the bucket's wheel. Ancient designs of the Pelton buckets were having half cylindrical buckets but the modern designs involves elliptical bucket with cutout at the center for smooth bucket entry of the water. Water leaves the bucket has a small velocity value and a slightly higher angle than 90° in order to avoid the striking of the water splashing out from the bucket to the next bucket. Modern Turbines produces power up to 450 MW with head ranges from 250 to 1900 m for

low output requirements, the horizontal shaft Pelton turbines with single or twin jets are used. For higher power output requirements, larger vertical shaft turbine units with multi jet nozzles are used

The general formula of any hydraulic system is as follows: $P = \eta \rho Q g$



Figure 6: Photograph of complete runner and buckets

Where,

P is the mechanical power produced at the turbine shaft in watts.

η is the hydraulic efficiency of the turbine.

ρ is the density of the water in kg/m³.

g is the acceleration due to gravity in m/s².

Q is the volume flow rate passing through the turbine in m³/s.

H is the effective pressure head of water across the turbine in meter.

For an impulse turbine of pelton wheel type, the mechanical power can be changed by means of changing η , Q and H inputs as g and ρ are constants.

A Pelton turbine consists of a set of specially shaped buckets mounted on a periphery of a circular disc. It is turned by jets of water which are discharged from one or more nozzles and

strike the buckets. The buckets are split into two halves so that the central area does not act as a dead spot incapable of deflecting water away from the oncoming jet. The cutaway on the lower lip allows the following bucket to move further before cutting off the jet propelling the bucket ahead of it and permits a smoother entrance of the bucket into the jet. The Pelton bucket is designed to deflect the jet through 165 degrees (not 180 degrees) which is the maximum angle possible without the return jet interference. The wheel of pitch diameter D has buckets around its periphery, so spaced that the jet always strikes more than one at a time. The buckets have the form shown at the upper left, where the water enters at a splitter and is diverted to each side, where the velocity is smoothly reversed. Bucket sizes are from 2.5 to 4 times the jet diameter. The total head supplying the nozzle is h , the sum of the pressure head and the approach velocity head. The theoretical jet velocity is $V = \sqrt{2gh}$. is u.

MODIFICATION OF THE PELTON WHEEL DESIGN

Pelton wheel is generally used for high head and low discharge applications. But it can be used for the low head also by adding some modifications in design. Splitters are used to increase the efficiency of the outlet of the water jet so that water can leave the bucket with a minimum velocity which is theoretically assumed tends to zero. The special modification is to increase the depth of the buckets which is not done in the usual pelton wheel buckets. In case of conventional Pelton wheel, only

kinetic energy of the jet impinged from the nozzle, is used but there is no application of gravity in the turbine action. In this gravitational low head Pelton wheel, both the kinetic and gravitational energy of the jet are used. The weight of this stored water per second in the bucket is the amount of potential energy per second from water jet.

Furthermore, this potential energy is converted into kinetic energy as this water filled bucket freely (assumed) falls. It is also possible to extract kinetic energy from the penstock nozzle discharge by means of a jet strike on the conventional Pelton-wheel vanes of the runner. This hydro system is good for a low-head and heavy-discharge application. Apart from this, gravitational energy of stored water is further extracted during emptying of bucket water by means of jet-propulsion under water head. This jet propulsion works on a runner wheel taking place due to the Gravitational-Force on bucket's stored water and results in a water jet discharge. Stored water of bucket enables delivery of two kinds of gravitational work on the runner wheel. They are in the form of kinetic energy conversion during its under-gravity free falling and in the form of jet-propulsion during its discharge from bucket-cup under gravitational pulling. In addition, as like Pelton-wheel, there is a provision for jet impulse on buckets. Aluminium is also used for its properties. So I used it in the place of runner for enhancing the speed of runner as well as the blade of runner which is mounted on the runner. Aluminium is the material that is suitable because doesn't rust, erode, corrosion and also it won't have an impact. **Figure 7**



Figure 7: Photographs of runner, buckets and casing mounted on top of the bearings

We will have to make use of ANSYS and Inventor stress analysis to analyses the stresses Equivalent (von-Mises) Stress and Total Deformation, as well Properties of the runner, for the design of the runner and measurement of tools Arc welding, Aluminium welding, measuring equipment. Rotalign laser alignment equipment to align the Alternator to the Pelton Wheel. Software packages include Microsoft Projects, Excel and Word. Quality documents must be drawn up to ensure the design of Pelton wheel runner with the buckets to take place according to our company standards and the needs of the clients.

Table 1: Table of materials, weights of the runner and overall weight of runner

S No	Material	Weight Of Runner (Kg)	Overall weight of Runner
1.	Stainless Steel	3.200	4.500 Kg
2.	Cast Iron s	2.7500	3.450 Kg
3.	Mild Steel	2.350	3.300kg
4.	Aluminium	0.550	0.750Kg

Methodology provides the successive information to achieve the objectives. The Methodologies in form of flow chart for analytical and simulation approaches also provides the overview of the way to achieve the objective. After the analysis and simulation a working model is fabricated as shown in figure

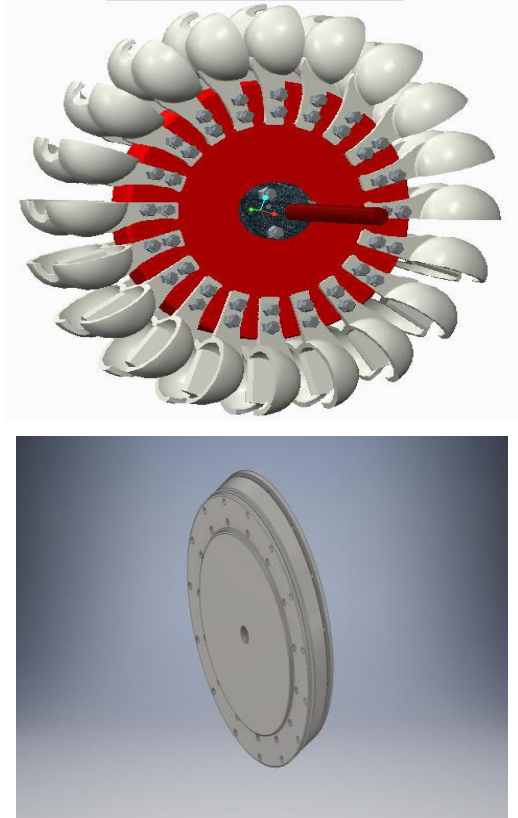

Figure 8: Assembly of pelton wheel turbine using Creo software and runner

Design of Pelton Wheel

The designing of the Pelton wheel consists of some design inputs, assumptions and design parameters.

Design Inputs:

Pressure head, $H = 1.5$ m

Power developed, $P = 0.25$ Kw

Assumptions:

Co-efficient of velocity of the nozzle, $C_v = 0.98$

Overall efficiency, $\eta_{\text{turbine}} = 85\%$

Ratio of peripheral velocity to jet velocity, $U/C_{\text{actual}} = 0.48$

Designed Parameters:

Diameter of the wheel = D

Diameter of the jet = d

Size of bucket i.e. Length = A

Width = B

Depth = C

Number of buckets = Z

Calculations:

Actual velocity of the jet, $C_{\text{actual}} = C_v \sqrt{2gh}$

$= 4.34$ m/s

Speed of the runner, $U = C_{\text{actual}} \times 0.48$

$= 2.08$ m/s

$= 0.43$ to 0.48

Flow rate, $Q = P / \rho g H \eta_{\text{turbine}}$

$= 0.388$ L/s

Diameter of jet, $d = \sqrt{4Q / \pi C_{\text{actual}}}$

$= 1.2$ cm

Diameter of the wheel, $D = 16 \times 1.2$

$= 19.2$ or, 20 cm here. $D/d = 16$

Number of buckets, $Z = 11 + D/2d$

$= 11.83$ or, 12

Size of Bucket: length, $A = 2.8d$ to $3.5d$

Or, $A = 4$ cm

Width, $B = 2.3d$ to $2.8d$

Or, $B = 3$ cm

Depth, $C = 2.5$ cm

Wheel velocity, $U = \pi D N / 60$

Or, $N = 198.625$ rpm

$= 3.31$ rps

The Specific Speed of a turbine is the speed in RPM at which a similar model of the turbine would run under a head of 1m. When of such a size as to develop 1 W. Note the suffix "s" is used to denote the values associated with the Specific Turbine.

For specific speed of turbine, $N_s = (N \sqrt{P}) / (H^{5/4}) = 119.625$ rpm

Specific speed is higher for the low head and high discharge. On the other hand it is lower for the high head and low discharge. It is a very important criterion for selecting a turbine for the same geometrical and dynamically similar turbines.

RPM of runner, $N = (U \times 60) / (\pi \times D) = 3.3$ rps

So, wheel diameter, $D = 20$ cm

Jet diameter, $d = 1.2$ cm

Buckets, $Z = 12$

Bucket length, $A = 4$ cm,

Width, $B = 3$ cm,

Depth, $C = 2.5$ cm

Specific speed = 119.65 RPM.

Experimental Setup

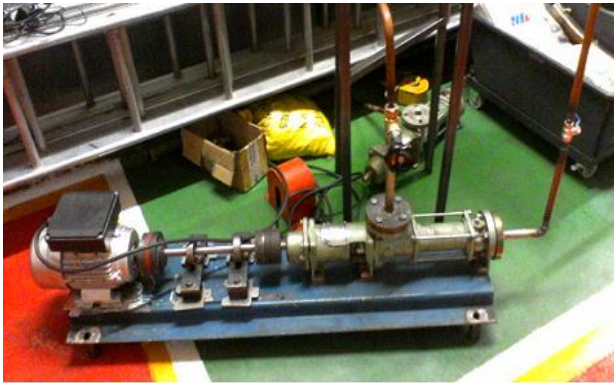

Figure 9: The photographs of Motor coupled to the pump modified/new plant design

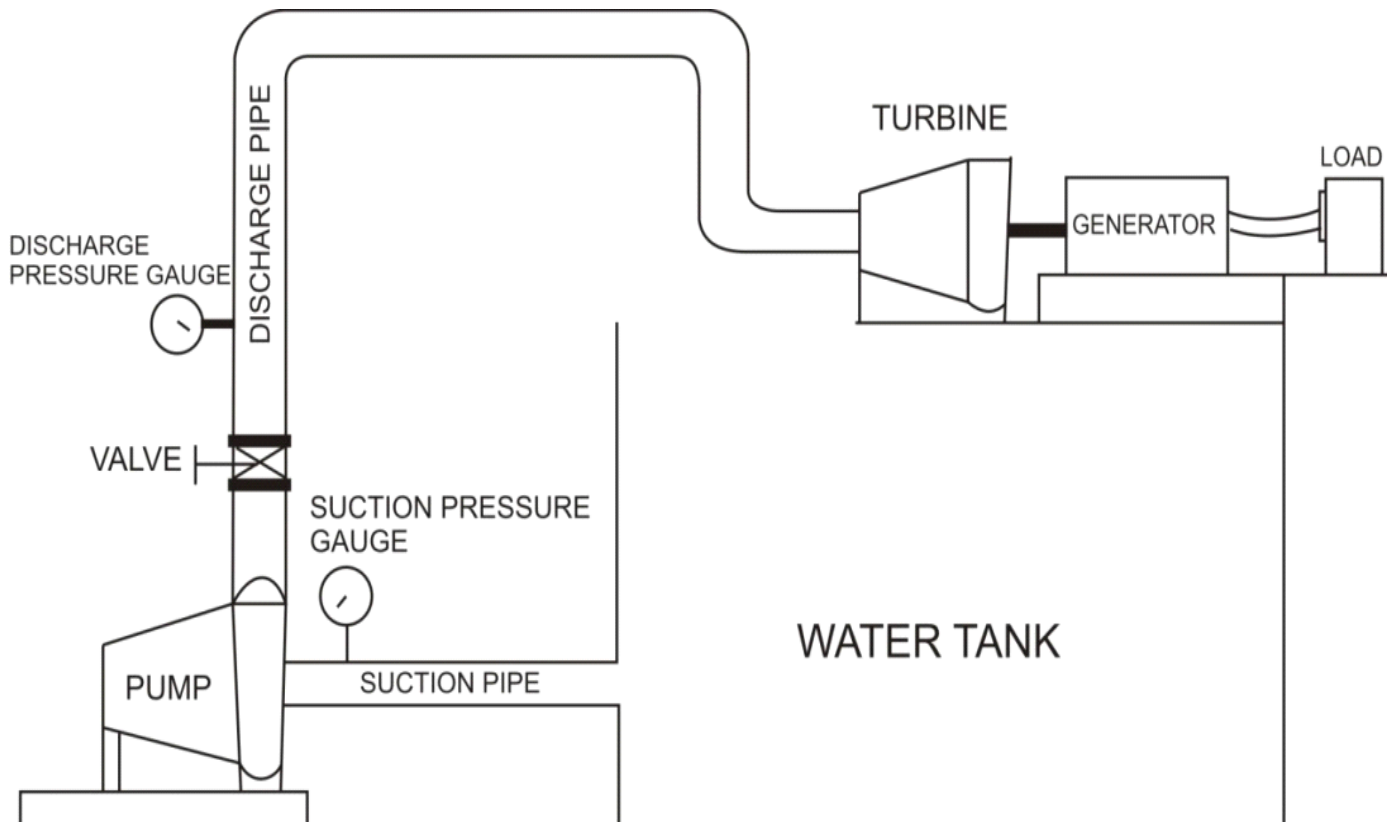

Figure 10: The schematic diagram of experimental setup modified/new plant design

A modified Pelton wheel is made which is consisting of runner, bucket with splitters, shaft, gearing arrangement, a small generator or dynamo etc. Data is collected using measuring instruments such as stop watch, beaker, tachometer, multimeter etc. A water tap (isolation flow control valve) from tank via pump and penstock used to create a orifice as a nozzle in order to have jet water so that we can the experiment.

Fig.4: Manufactured pelton wheel (Front & Side view)

RESULTS AND DISCUSSION

In the analysis of experimental data, it was found that maximum power produced 1.041 watt when maximum voltage is 3.01V for the maximum discharge of 156 mL/s.

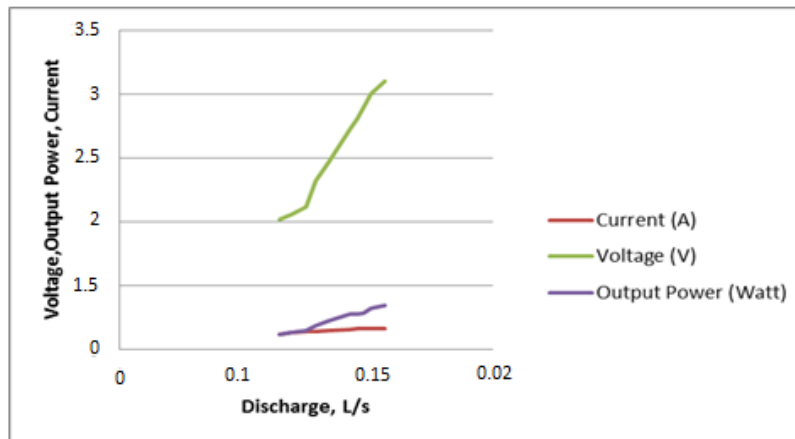

Figure. 11: Voltage, Output Power, Current vs. Discharge graph

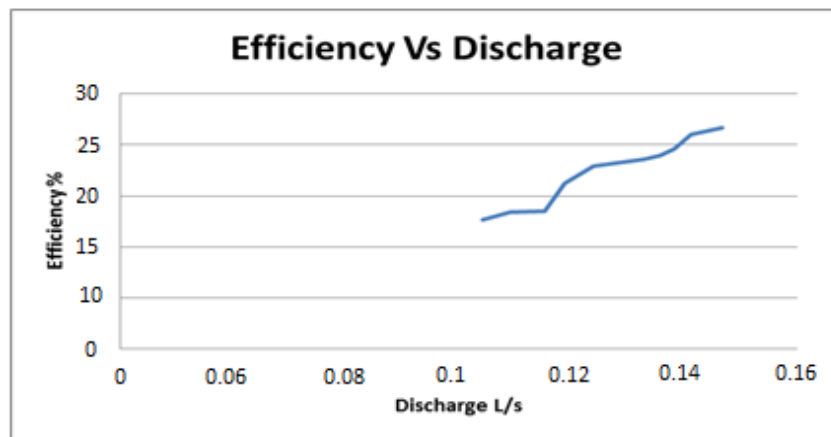

Figure. 12: Efficiency vs. Discharge graph

Experiment. From the graph of figure 11, we can see that each parameter is increasing with the increment of discharge. From efficiency vs. discharge graph of figure 6, we can also notice that the efficiency of the turbine is increasing significantly along with the discharge. It is due to that the inertia of wheel becomes more negligible with the increment of the discharge. When data was taken for this experiment, the discharge was not

so heavy. So the system loss was not recovered fully. It is noteworthy that the maximum efficiency was achieved is 21.65% for the maximum discharge. So, it can be said that to get high efficiency, the turbine is needed to be operated in high discharge applications. Improved gearing arrangement and larger buckets could give better efficiency as well.

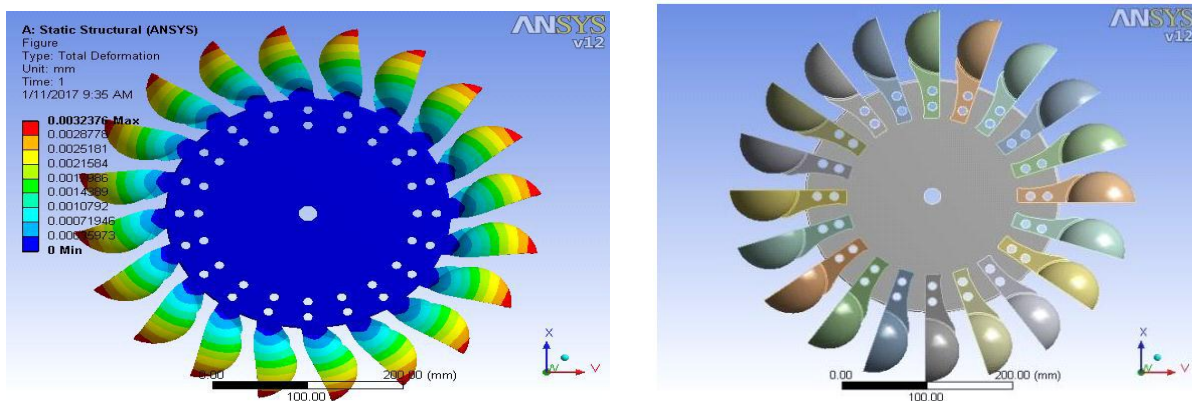

Figure 13: Equivalent stress of pelton runner Full and assembly ANSYS model of Pelton runner

There are diverse comes about were found at diverse control input for the distinctive runner materials of pelton wheel turbine. The speed of fly, release and control yield were found, and this test was performed on Stainless steel, Cast Iron, Gentle steel and Aluminium fabric of runner. These perusing are given underneath within the table: To begin with setup is on the Stainless steel material runner which could be a strong plate of 10 mm thickness.

Table 2: Result on changing on speed of runner due to velocity variation on Stainless steel runner

S No	Discharge (m ³ /s)	Velocity (m/s)	Power input (Watt)	RPM	u	Power output	Efficiency
1	0.001246	2.32	3.35	117.8	1.84	1.172	64
2	0.001655	2.96	7.25	156.5	2.45	1.654	56
3	0.001721	3.17	8.64	172.1	2.71	1.552	49

Result: We can see from the result that as the discharge increases the runner speed also increased. The maximum runner speed was noticed as 172.1 RPM at 0.001721 m³/s discharge and 3.17 m/s jet velocity.

Steel material runner which is a solid plate of 10 mm thickness. **Experiment-2** Fourth setup is on the Stainless material runner which is a solid plate of 5 mm thickness.

Table 3: Result on changing on speed of runner due to velocity variation on Aluminium runner

S No	Discharge (m ³ /s)	Velocity (m/s)	Power input (Watt)	RPM	u	Power output	Efficiency
1	0.001246	2.32	3.35	142.5	2.23	0.220	15
2	0.001655	2.96	7.25	189.5	2.9	0.195	8
3	0.001721	3.17	8.64	199.8	3.13	0.135	5

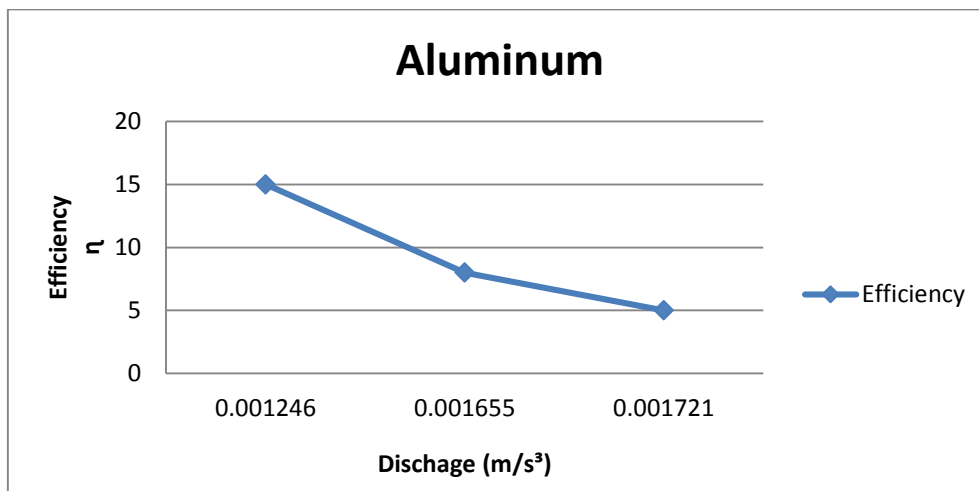

Figure 14: Graph of Efficiency against Discharge for Aluminum runner

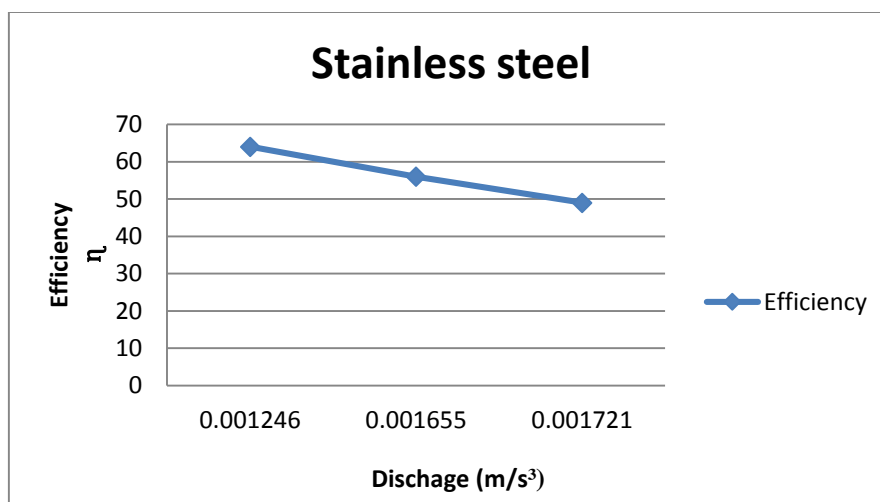

Figure 15: Graph of Efficiency against Discharge for Stainless steel runner

This venture work contains considers on the speed of distinctive fabric rotor which is works on distinctive release and impact on the proficiency of plant. The strong demonstrate of pelton wheel turbine has been created in Creo program and all examination was performed in ANSYS 12.0 computer program. This chapter covers the conclusion of the proposal work. The display work was based on to check the execution of pelton wheel turbine by utilizing distinctive runner fabric. In this test consider Stainless steel, cast press, mellow steel and Aluminium rotors were utilized. To execute test consider plan of physical demonstrate of pelton wheel turbine was done. To compare the execution of distinctive runners materials release, speed, relative speed, control input, control yield and effectiveness was measured at distinctive speeds. This work was carried at changing speeds for same fabric of runner shaft conjointly this method was done for all materials of runners.

It was observed in to begin with explore that at 2.32 m/s and 0.00125m³/s for the Stainless steel runner the RPM was 117.8 whereas 122.5, 137.5 and 142.5 for Cast steel, Gentle steel and Aluminium individually. From try to begin with it was watched that at the same speed Aluminium runner gives most extreme RPM (142.5) on the other hand cast press runner gives least RPM (117.8). Same strategy was carried out for explore moment and third at distinctive speeds for distinctive materials of runner. After analysing these comes about from all three tests it can be said that the Bakelite runner gives most extreme RPM

as compare to wooden, strong cast press and empty cast press runners. Moreover these comes about appears that the strong cast press runner gives least RPM as compare to Stainless Steel, Mellow Steel and Aluminium runners. These tests were done at moo head so we will conclude that Aluminium runner is exceptionally advantageous as compare to other three materials we utilized at moo head. We know that Pelton wheel turbine. The above calculations have proven that the selected pipes will be suitable to deliver the required test facility output and the conclusion is that the conducted analysis for the piping system satisfies all the stated criteria for the specific application. The selected valves for both suction and discharge lines are suitable for the design requirements, the rated pressure for each valves is sufficient and geometrically they fit the purpose and the material of construction is also suitable for transporting water

Table 4: Result of Discharge, head available and head required

Discharge(Q) (m ³ /min)	0	5.0	9.0	13.5	18.0	22.5
Head available (m)	22.5	22.2	21.6	19.5	14.1	0
Head required(m)	15	15.4	16.6	18.6	21.5	25.1

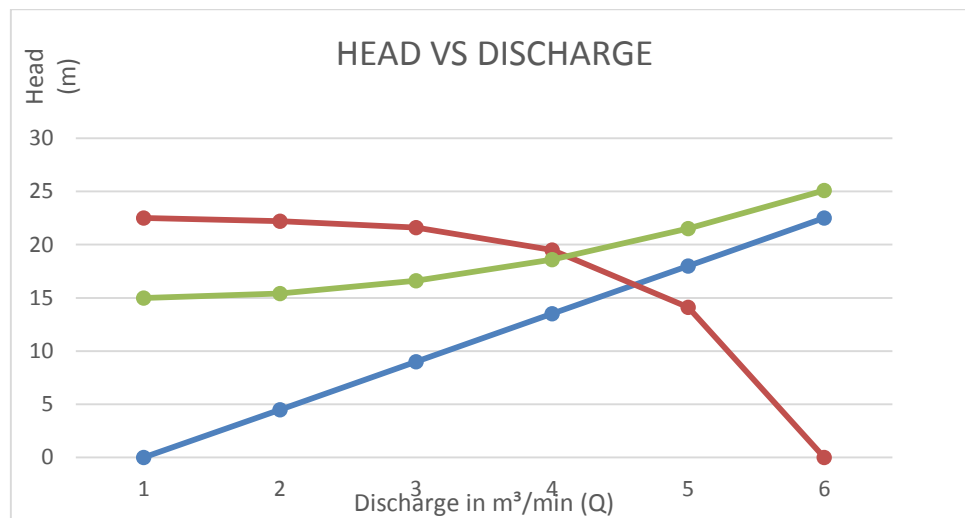

Figure 16: Graph of pump performance between head flow rate

The to begin with step of this inquire about was collecting specialized information and determination of the pump utilized for Pelton turbine and those for power generator determination. The information was utilized to plan the Pelton turbine. Furthermore, the materials for Pelton turbine bucket and spout were gotten from a few shops and fabricate companies for making the specified sort of Pelton turbine bucket and spout at workshop based on the collected information. At that point, two sorts of Pelton turbine buckets, two sorts of needle situate ring, and three sorts of needle tip were fabricated. Following, the volume of to begin with example bucket was +15% of the standard volume with the point of 92° though that of the

moment example bucket was -15% of the standard volume with the point of 88°. Both had the same or less weights when compared to that of standard bucket. In conclusion, the Pelton turbine buckets were tested. The test was executed within the conditions of 100%, 80%, 60% and 50% of the valve position to examine the expanding proficiency. The tests moreover pointed at examining the distinction of the water stream of the modern buckets from the standard one as to discover out the power of generator influenced by the stream of spout. Based on the comes about of tests, the leading volume for Pelton turbine buckets was chosen.

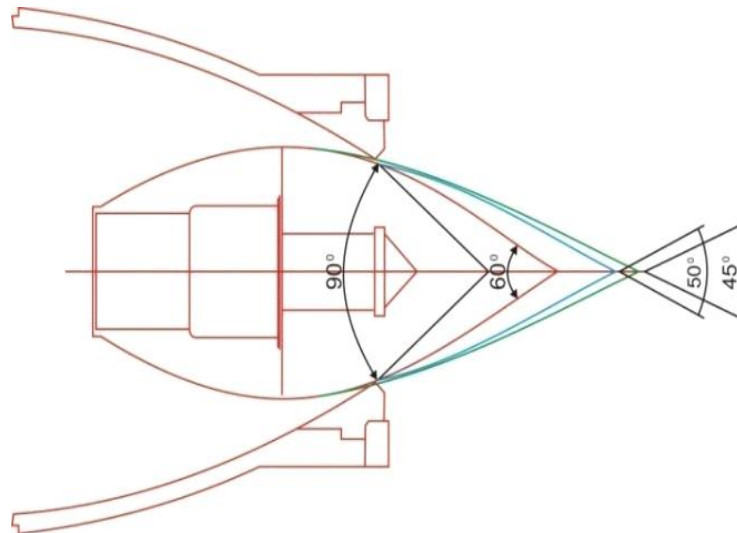

Figure 17: Graph of Constant results of all buckets in nozzle 90° needle seat ring, 60° needle tip

Table 5: Constant results of all buckets in nozzle 90° needle seat ring, 60° needle tip

	Opening Valve	P suction (meter)	P discharge (meter)	Head (meter)	Flow Rate (m ³ /s)	P input (watt)
Nozzle needle seat ring 90°, needle tip 60°	50%	-0.408	11.5	11.908	0.000673	78.664
	60%	-0.516	14.0	14.516	0.000755	107.479
	80%	-0.544	15.0	15.544	0.000806	122.973
	100%	-0.680	15.5	16.18	0.000847	134.513
Nozzle needle seat ring 90°, needle tip 50°	50%	-0.884	5.7	6.584	0.000889	57.412
	60%	-1.292	9.5	10.792	0.001105	116.982
	80%	-2.176	10.5	12.676	0.001198	148.924
	100%	-2.380	12.0	14.38	0.001307	184.402
Nozzle needle seat ring 90°, needle tip 45°	50%	-0.952	2.0	2.952	0.000905	26.207
	60%	-1.768	6.5	8.268	0.001223	99.216
	80%	-2.584	10.0	12.584	0.001493	184.252
	100%	-2.951	11.0	13.951	0.001646	225.286

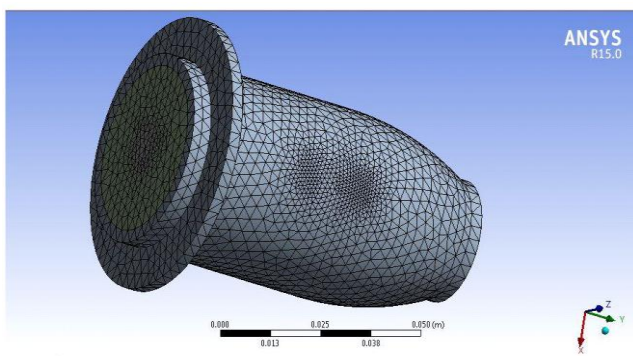

Figure18: Mesh report of standard nozzle Model (D3) > Mesh

In table1, the person consistent comes about of the three sorts of turbine bucket. The comes about are settled at the same valve position. The primary column after valve position is the suction weight, taken after by suction weight converter to the meter, and after that the release weight, taken after by release weight converter to the meter and the column head, which is the entirety decrement the suction weight of the release weight. In this way, the more opening valve, the higher the head it accomplishes.

CONCLUSION

With the modified upgraded gravitational Pelton-wheel is more effective for low-head and heavy discharge applications. For

the same head condition, heavy electrical generators can be used for the modified gravitational Pelton-wheel than the conventional Pelton-wheel. The energy content in the runner shaft is lower in the conventional Pelton wheel. The modified wheel is more competent than the conventional impulse and reaction turbines. The development and fabrication of this turbine is not so tough in industrial aspects due to the available fabrication techniques of welding in the industrial workshops. However, it is not so easy to fabricate manually rather than industrial aspects. The more efficient wheels require accurate design and precise fabrication techniques. Due to the larger bucket sizes, it requires precise balancing of mass and reducing the losses due to bearing and wind resistance to get the maximum efficiency. However, it is desired that the much better and efficient Pelton wheel will be designed in future improving the bucket design to utilize the maximum energy of water jet.

RECOMMENDATIONS

It can be recommended to minimize the inertial losses to increase the efficiency. Tachometer should be attached to read the rpm continuously. The shaft should be kept straight as much as possible to keep the output constant. This type of turbine with large scale design can be used in large discharging canals or water exhausting system of different industries for producing power to electrify the isolated rural areas. For example, it is possible to use the cooling water exhaust of a thermal power plant to produce about 0.25 kW of power that can be used for electrification purposes. Pelton turbines are not used at lower heads because their rotational speeds become very slow and the runner required is very large and bulky. If runner size and low speed do not pose a problem for a particular installation, then a Pelton turbine can be used efficiently with low heads. If a higher running speed and smaller runner are required, then there are two further options are available such as increasing the number of jets and using twin runners.

8. ACKNOWLEDGEMENT

This material is based on the work which is supported financially by the National Research Foundation (NRF) and Vaal University of Technology (VUT).

REFERENCES

- [1] David Halliday, Robert Resnick and Jearl Walker (2004), *Fundamental of Physics (Sixth Edition)*, John Wiley & Sons, Inc., New York.
- [2] Hugh D. Young, and Roger A. Freedman (1998), *University Physics (Ninth Edition)*, Addison Wesley Longman, Inc., New York, 1998.
- [3] Victor L. Streeter and E. Benjamin Wylie (1981), *Fluid Mechanics*, McGraw-Hill Book Company New York.
- [4] Robert L. Daugherty, Joseph B. Franzini, E. John Finnemore (1989), *Fluid Mechanics with Engineering Applications*, McGraw-Hill Book Company, New York.
- [5] Suraj Yadav, "Some Aspects of Performance Improvement of Pelton Wheel Turbine with Reengineered Blade and Auxiliary Attachments", *International Journal of Scientific & Engineering Research*, Vol. 2, Issue 9, September-2011, ISSN 2229-5518
- [6] "Small & Micro Hydropower", Volume 9, Issue 4, www.smallhydro.com, Accessed 28/10/2011
- [7] "Lester Allan Pelton." <http://www.vermilionohio.org/>. Accessed 20/10/2011.
- [8] International Conference on Mechanical Engineering and Renewable Energy 2015 (ICMERE2015) 26 – 29 November, 2015, Chittagong, Bangladesh
- [9] Sob, P. B. Pita, M. A. Tengen, T. B. "Modeling Strain Rate Sensitive Nanomaterials' Mechanical Properties: the effect of varying definitions, M. Tech. Dissertation. Vaal University of Technology, 2016
- [10] Sob, P. B. Pita, M. Tengen, T. B. Stochastic Model of Nano crystalline Materials Energy Produced by Accumulative Roll-Bonding. 10th South African Conference on Computational and Applied Mechanics Potchefstroom 3-5 October 2016
- [11] Sob, P. B. Pita, M. Tengen, T. B. The Effects of the Size Variants of Nano crystalline Materials Produced by Accumulative Roll-Bonding on their Energy, Thermodynamics and Mechanical Properties. *10th South African Conference on Computational and Applied Mechanics Potchefstroom 3-5 October 2016*
- [12] TENGEN, T. B. 2008. Analysis of Characteristic of Random Microstructures of Nanomaterials PhD. Thesis. Witwatersrand Johannesburg.