

## **A Study on Production Development and Management**

**Yad Ram Singh<sup>1</sup> and Suraj Kumar<sup>2</sup>**

*<sup>1</sup>Department of Mechanical Engineering, Pornima College of Engineering,  
Jaipur G-582, Makarwali Road, Near Bank of India, Vaishali Nagar,  
Ajmer Rajasthan-305001.*

*<sup>2</sup>Department of Mechanical Engineering, Bhagwant University, Ajmer.*

### **Abstract**

Production Development and Management is the leading management approach that companies employ to improve their product and service quality with the aim of improving typical measures of business performance (e.g. increased profits, increased market share, reduced costs and best quality). Customer requirement management entails various issues related to requirement elicitation, analysis, and specification, as well as the requirement management process. The study describes and evaluates the concepts and techniques in the development processes and the applications of an organization. We focus to examine what quality means across these organizations and to discover the differences between methodologies that do or do not apply Production Development and Management concepts. This paper offers a relationship between components, customer and supplier interactions and measures of company performance by developing a framework, which is tested and refined through a study of manufacturing company. This also explores the complex relationship between organizational context and knowledge management.

**Keywords:** Production Management, profit, performance.

### **1. Introduction**

Production is the process by which raw materials and other inputs are converted in to the finished goods. Operations management has been recognized as an important factor in a country's economic growth in service sector which become more famous. Rapid changes posed numerous opportunities and challenges. Our general aims in this study

are to bring new experiences and knowledge on requirement management in the production and its development. This system has major challenges in the global competitive environment. Today's effective product development is not characterized on the creativity, but it depends on the management. This paper, review the production Management and launching to improve the productivity and represents the relationship between top down and bottom up approach to achieve goals. We refer to as requirements management, involve several disciplines and extend through all development phases. The activities which are involved in manufacturing is called as production management. If same concept involved in services management is called as operation management.

## 2. Literature Review

### 2.1 Ways of production

1. **Production by Disintegration:** By separating the contents of Crude oil or a mixture by which the desired products are produced. For example the crude oil is disintegrated into various fuel oils. Similarly salt production is also an example for.
2. **Production by Integration:** In this type of Production various Components of the products are assembled together to get the desired product. In this process, Physical and Chemical Properties of the materials used may change. The examples are: Assembly of Two wheelers, four wheelers and so on.
3. **Production by Service:** Here the Properties of materials (Chemical and Mechanical) are improved without any physical change. Example:-Heat Treatment of metals.

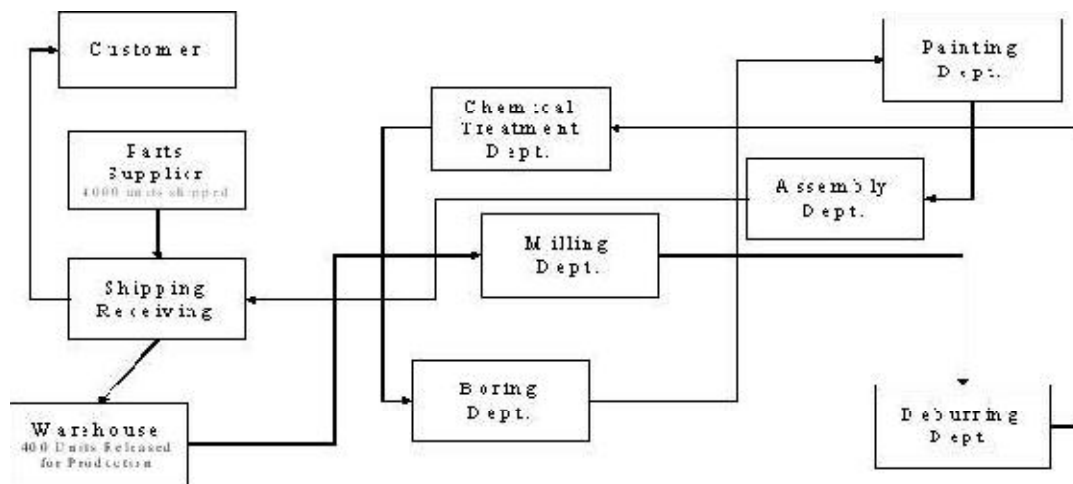
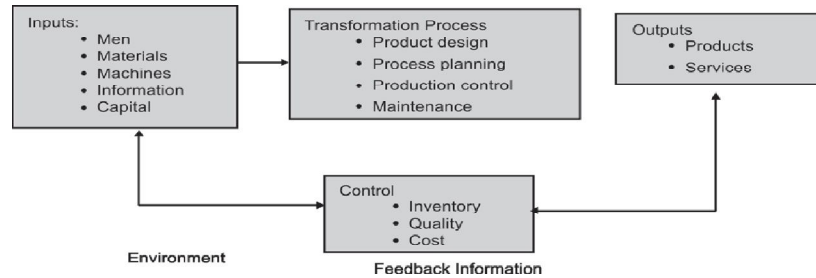

Figure 1: Production-Aligned ways for integration and other.

**2.2 Production System:-**



**Figure 2.2:** Production-Aligned Procedure of production.

**2.3 Characteristic of production system :-**

1. Production system has an own objective.
2. The system transforms the various inputs to useful outputs.
3. It does not operate in isolation from the other organization system.
4. There exists a procedure which control and improve system performance.

**2.4 Types of production:-**

1. Continuous Production
2. Batch Production
3. Mass Production
4. Job-Shop Production.

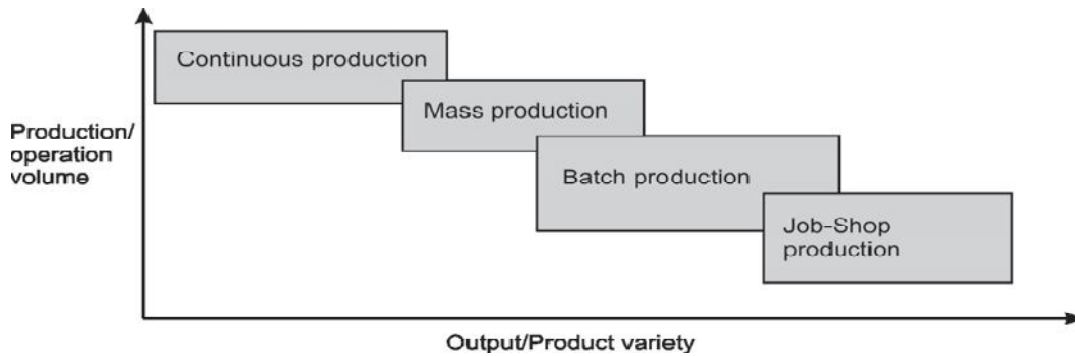

**Figure 3:-**Category-Aligned production types.

**3. FINDING A. Example which implement it**

**3. 1 WEGMANS FOOD MARKETS**

Wegmans Food Markets, is one of the premier grocery chains in the United States,.Wegmans have more than 70 stores. The company has annual sales of over Rs. 2.0 billion. It has a strong reputation for offering its customers high product quality and

excellent service. 2. **DFMA** also implements this process .Other examples are TATA Motor, Nokia phone and So many companies. 3. **Toyota Motor Company**: Toyota evolved a unique manufacturing system which main aim is zero defects .As per example it implement Kanban technology. Kanban is a technique that's used to bring about an action .Toyota introduced and refined the use of kanban to standardize the flow of parts in their production and development to ensure that inventory was based on actual customer orders rather than managerial forecasts. Kaban is a card with an inventory number, attached to a part before the part is installed and manufacture that part for which card is given.

### 3.2 Six rules which characterize the “ KANBAN”

1. Downstream processes may only withdraw on the specified amounts.
2. Upstream processes may only send items
3. Without a kanban no items are made or moved .
4. 4 For each item, a kanban must accompany at all times.
5. Defects and incorrect amounts are never sent.
6. For improvement the number of kanbans should be monitored carefully to allow something hidden to be seen the problems.

### 3.3 Techniques of “ KAIZEN”

Safety Kaizen is a system of continuous improvement in quality, technology, processes, company culture, productivity, safety and leadership. Kaizen is based on making little changes on a regular basis always improving productivity, and effectiveness while reducing wastage .

### 3.4 Kaizen 5S Principle

1. SEIRI - Sort, Clear Out
2. SEITON - Set Things in Order
3. SEISO - Clean and Shine
4. SIEKETSU – Standardize
5. SHITSUKU - Self Discipline

## 4. Objectives

### 4.1 Objects of production management

1,Right quality 2.Right quantity 3.Right time 4.Right Manufacturing Cost 5.Main aim is to adopt six sigma. And most important thing is to produce the desired product or specified product by specified methods. Production management as a function of manufacturing, retailing, transportation, whole selling.

### 4.2 Productivity analysis

1. **Trend analysis**: Studying productivity changes for the firm over a period of time.
2. **Horizontal analysis**: Studying productivity in comparison with other firms of same size and
3. Engaged in similar business.

4. **Vertical analysis:** Studying productivity in comparison with other industries and other firms.
5. **Budgetary analysis:** Setting up a norm for future productivity.

**4.3 Strategic planning:-**

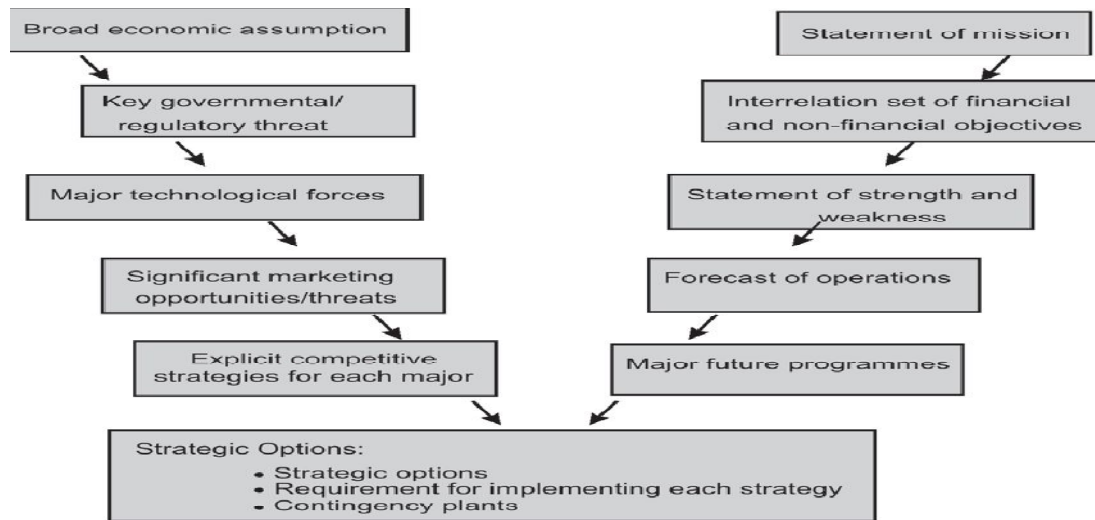

**Figure 3:** Planning-Aligned, for Production.

**4.4 Chart for P.P.C. Department:-**

- |                      |                           |
|----------------------|---------------------------|
| 1. Order of Booking  | 2. Dispatching            |
| 3. Stores management | 4. Production             |
| 5. Budget            | 6. Material Records       |
| 7. Expediting        | 8. Quality Control method |
| 9. Machines          | 10. Handlin               |
| 11. Receiving        | 12. Tools and Jigs        |
| 13. Operation Layout | 14. Simplification        |
| 15. Time estimating  | 16. Standardization       |

**5. Conclusion:-**

Production management focuses on carefully managing the process to produce and to distribute products and services. We believe that product lines present an opportunity for increased efficiencies and economies, more reliable and predictable and higher quality production, a more robust relationship with a production, launching and management in current and new markets A great deal of focus is on efficiency and

effectiveness of processes development .It improve the productivity and represents the relationship between top down and bottom up approach to achieve goals. Therefore production development and management often include substance measurement and analysis of all the internal activity .This paper will help more organizations make the attempt .At last we concluded that management is not only a important key but also play a vital role in before the production and after it also.

## Reference

- [1] Administration industrially general purveyance organization -commandment, co ordination controlee, Paris Dunned,1966
- [2] Journal of Operations Management 17 \_1998. 23–37
- [3] Vocationa Business: Training, Developing and Motivating People by Richard Barrett - Business & Economics - 2003. - Page 51
- [4] Key to the Success of a Product and Even of the Company Behind It." *The Financial Times*.27February2006
- [5] K. Shridhara baht ,K Aswathappa
- [6] S. Anil Kumar and N.SURESH
- [7] Juneau hub Juneau, First Himanshu , and Preachy Juneau. "Management ." Management Study Guide. Web Craft Put Ltd, 2011. Web. 17 Mar2011